

THROUGH THE WALL ROOM AIRCONDITIONER

Service Manual



I. Summary and Features

Summary:

The unit is the packaged one, including the indoor part and the outdoor part. The unit is installed in the hole pre-embedded in the wall, which is different from traditional installation and prettifies the room, without occupying the space.

Features:

- a. Easy installation: Install the drainage pipe at first, and then push the unit into the installed cabinet assy. At last, turn the safety clamp for 90 degrees to finish.
- b. Easy cleaning and maintenances: Pull the unit out and unscrew the 6 screws used for fixing the cover plate to remove it. In this case, condenser can be cleaned with water. At last, lift the unit slightly to drain the water.
- c. High energy efficiencies: the unit meet for the latest DOE requirement and the AHRI standard.
- d. Silent design: optimized air discharge channel design, specialized blower wheel, the lower rotational speed, contributing better noise control.

Nomenclature:

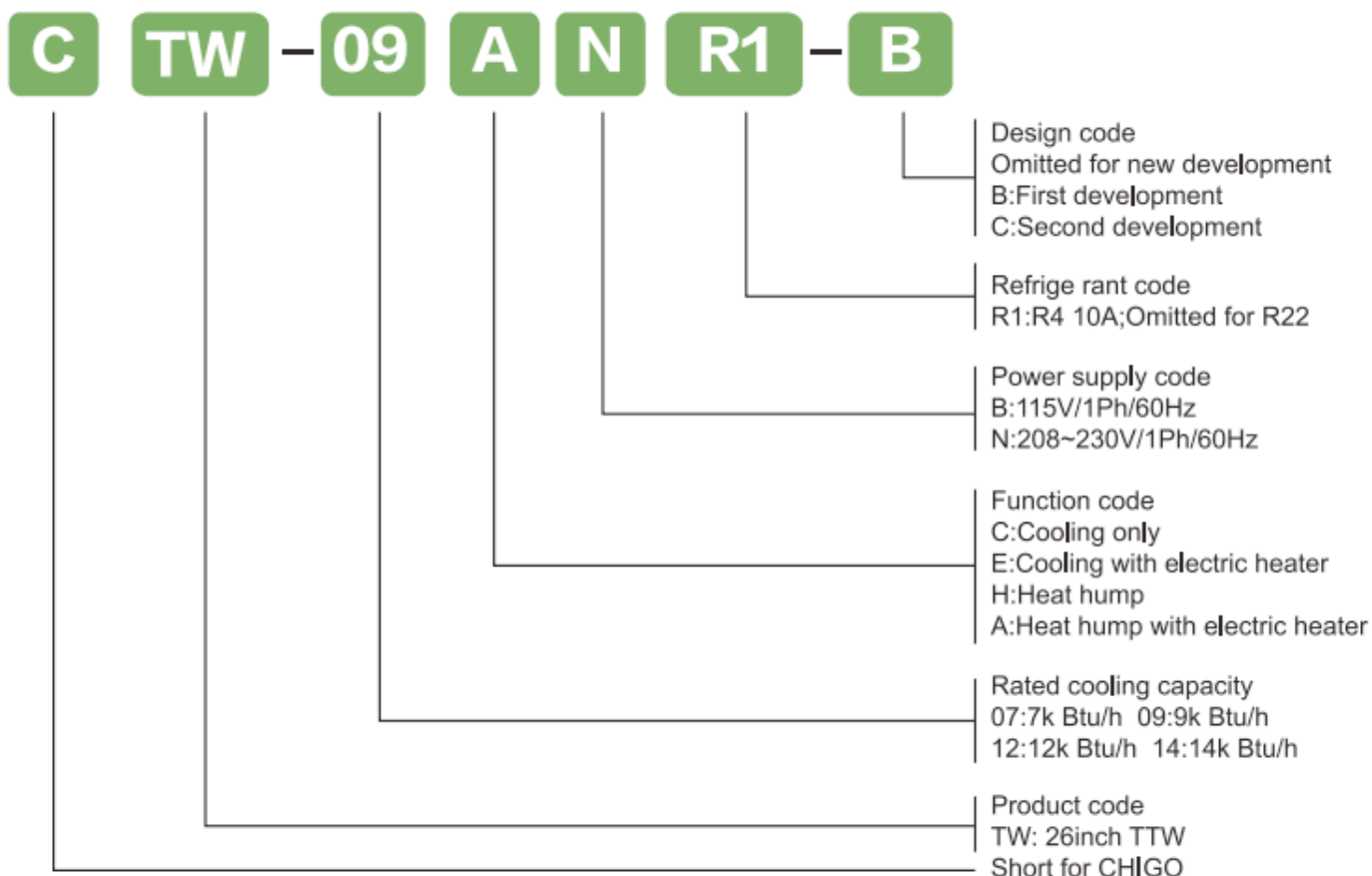

II Specification and Technical Parameter

208~230V Cooling only

Model			CTW-09CNR1-B	CTW-12CNR1-B
Power supply		V-Ph-Hz	230/208V/1Ph/60Hz	230/208V/1Ph/60Hz
Cooling	Capacity	Btu/h	9400/9300	11800/11600
	Input	W	940/910	1185/1145
	EER	Btu/h.W	10.0/10.2	10.0/10.1
Heating	Capacity	Btu/h	/	/
	Input	W	/	/
	COP	Btu/h.W	/	/
Electric heater		KW	/	/
Compressor Brand			RECHI	GMCC
Indoor side performance	Air flow (Hi)	m3/h	460	460
	Noise level	dB(A)	60/58/55	60/58/55
Net Dimension(W*D*H)		mm	660×548×396	660×548×396
Packing dimension (W*D*H)		mm	765×630×480	765×630×480
Net/Gross weight		LBS	80.5/90.5	82/91.5
Refrigerant	Charged volume	g	560	600
Qty'per 20'40'40HQ		Set	108/216/285	108/216/285

208~230V Cooling with electric heater

Model			CTW-09ENR1-B	CTW-12ENR1-B
Power supply		V-Ph-Hz	230/208V/1Ph/60Hz	230/208V/1Ph/60Hz
Cooling	Capacity	Btu/h	9400/9300	11800/11600
	Input	W	940/910	1185/1145
	EER	Btu/h.W	10.0/10.2	10.0/10.1
Heating	Capacity	Btu/h	/	/
	Input	W	/	/
	COP	Btu/h.W	/	/
Electric heater		KW	3.4	3.4
Compressor Brand			RECHI	GMCC
Indoor side	Air flow (Hi)	m3/h	460	460

THROUGH THE WALL ROOM AIRCONDITIONER

performance	Noise level	dB(A)	60/58/55	60/58/55
Net Dimension(W*D*H)		mm	660×548×396	660×548×396
Packing dimension (W*D*H)		mm	765×630×480	765×630×480
Net/Gross weight		LBS	83/93	84/94
Refrigerant	Charged volume	g	560	600
Qty'per 20'40'40HQ		Set	108/216/285	108/216/285

208~230V Heat pump with electric heater

Model			CTW-07ANR1-B	CTW-09ANR1-B	CTW-12ANR1-B
Power supply		V-Ph-Hz	230/208V/1Ph/60Hz	230/208V/1Ph/60Hz	230/208V/1Ph/60Hz
Cooling	Capacity	Btu/h	7400/7200	9300/9100	11700/11500
	Input	W	695/675	940/910	1185/1145
	EER	Btu/h.W	10.6/10.6	9.9/10.0	10.0/10.1
Heating	Capacity	Btu/h	6800/6600	8800/8600	11400/11200
	Input	W	640/620	830/810	1115/1090
	COP	Btu/h.W	3.1/3.1	3.1/3.1	3.0/3.0
Electric heater		KW	3.4	3.4	3.4
Compressor Brand			RECHI	RECHI	GMCC
Indoor side	Air flow (Hi)	m3/h	460	460	460
performance	Noise level	dB(A)	60/58/55	60/58/55	60/58/55
Net Dimension(W*D*H)		mm	660×548×396	660×548×396	660×548×396
Packing dimension (W*D*H)		mm	765×630×480	765×630×480	765×630×480
Net/Gross weight		LBS	84/94	84/94	110.5/97
Refrigerant	Charged volume	g	499	560	900
Qty'per 20'40'40HQ		Set	108/216/285	108/216/285	108/216/285

115V Cooling only

Model			CTW-12CBR1-B	CTW-09CBR1-B
Power supply		V-Ph-Hz	115V/1Ph/60Hz	115V/1Ph/60Hz
Cooling	Capacity	Btu/h	11800	9000
	Input	W	1200	920
	EER	Btu/h.W	10.6	9.8
Heating	Capacity	Btu/h	/	/
	Input	W	/	/
	COP	Btu/h.W	/	/
Electric heater		KW	/	/

THROUGH THE WALL ROOM AIRCONDITIONER

Compressor Brand			GMCC	RECHI
Indoor side performance	Air flow (Hi)	m3/h	490	490
	Noise level	dB(A)	59/57/55	59/57/55
Net Dimension(W*D*H)		mm	660×548×396	660×548×396
Packing dimension (W*D*H)		mm	765×630×480	765×630×480
Net/Gross weight		LBS	84/94	80.5/90.5
Refrigerant	Charged volume	g	819	540
Qty'per 20'40'40HQ		Set	108/216/285	108/216/285

115V Heat pump with electric heater

Model		CTW-09ABR1-B	
Power supply		V-Ph-Hz	115V/1Ph/60Hz
Cooling	Capacity	Btu/h	9000
	Input	W	920
	EER	Btu/h.W	9.8
Heating	Capacity	Btu/h	8500
	Input	W	805
	COP	Btu/h.W	3.1
Electric heater		KW	1.2
Compressor Brand		RECHI	
Indoor side performance	Air flow (Hi)	m3/h	460
	Noise level	dB(A)	59/57/55
Net Dimension(W*D*H)		mm	660×548×396
Packing dimension (W*D*H)		mm	765×630×480
Net/Gross weight		LBS	84/94
Refrigerant	Charged volume	g	540
Qty'per 20'40'40HQ		Set	108/216/285

III Parts' Name

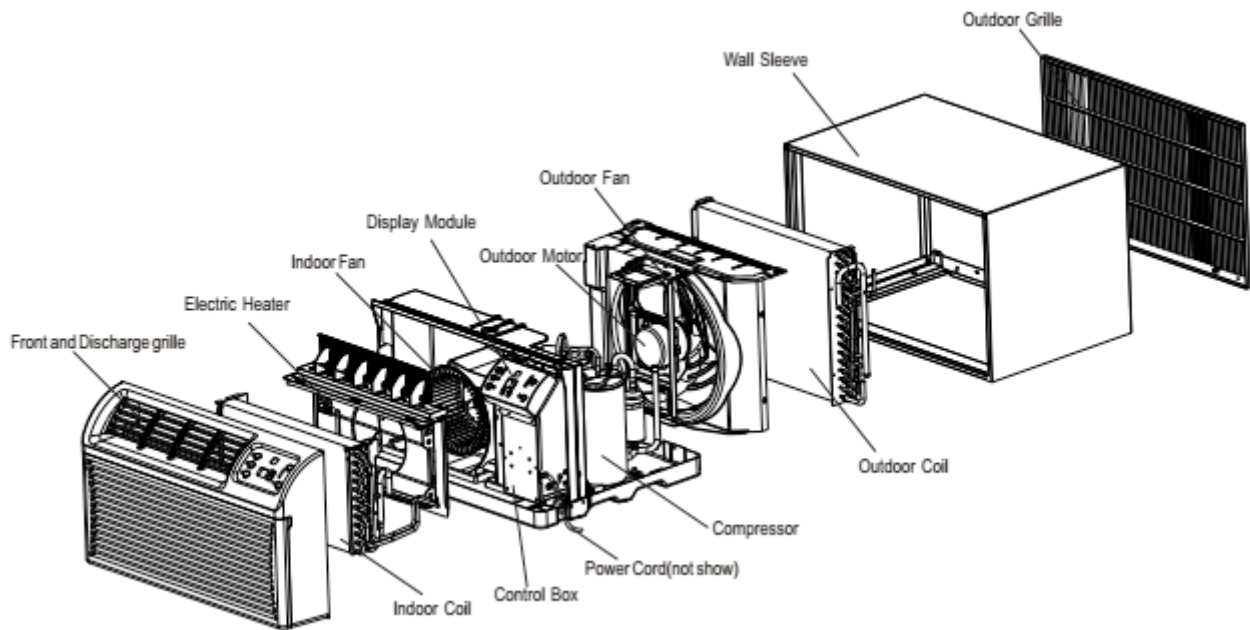

Wall sleeve: all our sleeves have industry standard dimensions of 26" wide x $15\frac{3}{4}$ " high. The $16\frac{3}{4}$ " depth is the industry

standard. Sleeves may be shipped separately to allow for installation during construction.

Outdoor grill: available in stamped aluminum louvered for application with wall sleeve.

Condensate drain kit: attaches to the wall sleeve base pan for controlled internal or external disposal of condensate.

IV Controller Function Manual and Operating Method

Controller Function Manual

This function manual is applicable to TTW. The unit for temperature is centigrade. If there's Fahrenheit, their transition relations is $T_{\text{Fahrenheit}} = T_{\text{centigrade}} * 1.8 + 32$.

1. Temperature Parameter
 - ◆ Indoor setting temperature (T_{preset})
 - ◆ Indoor ambient temperature (T_1)
2. System Basic Function

In any circumstances, the compressor will delay 3 mins for protection once it's started up. Once the compressor is started up, the compressor won't stop with the change of the indoor temperature. While once the compressor is stopped, it can be started up only after 3mins delayed. (The compressor can be stopped immediately at the time of mode switchover, turning off the unit, adjusting setting temperature and turning to protection functions.)

1) Cooling Mode

Working conditions and process for cooling:

When $T_1 \geq T_s + 2^\circ\text{F} (1^\circ\text{C})$, the unit is running in cooling mode. Meanwhile, the compressor is running and the fan is running at the setting fan speed;

When $T_1 \leq T_s - 2^\circ\text{F} (1^\circ\text{C})$, the unit is turn to OFF status. Meanwhile, the compressor will stop, while the fan will run at the setting fan speed for 15s delay;

When $T_s - 2^\circ\text{F} (1^\circ\text{C}) < T_1 < T_s + 2^\circ\text{F} (1^\circ\text{C})$, the unit keeps previous running status.

◇ In this mode, the dual 8 nixie tube displays the setting temperature and the cooling LED is bright. The setting temperature range is $60 \sim 90^\circ\text{F} (16 \sim 32^\circ\text{C})$.

2) Fan Mode

In this mode, the compressor won't run and the temperature can't be adjusted (UP and DOWN are invalid).

The fan can select high, medium and low fan speed to run.

3) Auto Fan Mode

When cooling starts, if $T_1 \geq T_s + 4^\circ\text{F}$, indoor fan runs high speed. And then when $T_1 \leq T_s + 1^\circ\text{F}$, indoor fan runs low speed. And when $T_1 \leq T_s - 1^\circ\text{F}$, indoor fan off. When heating starts, if $T_1 \geq T_s + 1^\circ\text{F}$, indoor fan runs low speed. And when $T_1 \leq T_s - 1^\circ\text{F}$, indoor fan off.

When heating starts, if T_2 (indoor coil temperature) $\geq 97^\circ\text{F} (36^\circ\text{C})$, indoor fan runs high speed. And then when $T_2 \leq 90^\circ\text{F} (32^\circ\text{C})$, indoor fan runs low speed. When heating starts, if T_2 (indoor coil temperature) between 86°F and 97°F , indoor fan runs low speed. And when $T_2 \leq 68^\circ\text{F} (20^\circ\text{C})$, indoor fan off.

4) Heating Mode

Working condition and process for heating:

When $T_1 \leq T_s - 2^\circ\text{F} (1^\circ\text{C})$, the unit is running in heating mode. Meanwhile, the compressor is running and the fan is running at the setting fan speed;

When $T_1 \geq T_s + 2^\circ\text{F} (1^\circ\text{C})$, the unit is turn to OFF status. Meanwhile, the compressor will stop, while the fan will run at the setting fan speed for 15s delay;

When $T_s - 2^\circ\text{F} (1^\circ\text{C}) < T_1 < T_s + 2^\circ\text{F} (1^\circ\text{C})$, the unit keeps previous running status.

THROUGH THE WALL ROOM AIRCONDITIONER

Electric-heater can't work with compressor at the same time. When $T_1 < 44^\circ\text{F}$ (7°C), unit will run with Electric-heater, when $T_1 \geq 44^\circ\text{F}$ (7°C), unit will run with compressor.

5) Room freeze Protection

This is valid in standby cooling and fan mode.

Entry condition: If dial-up chooses the room freeze protection and it's detected that the indoor ambient temperature is lower than 50°F (10°C) for 3mins successively .

Quitting condition: When the indoor ambient temperature is raising more than 55°F (13°C), room freeze protection will be stopped.

After entering into the low temperature resistant protection, it can't be quitted by pressing any buttons ;(except the heating mode) Others: In the low temperature resistant protection, the dual 8 displays "L0".

6) Open circuit and short circuit of temperature sensor

If the temperature sensor is open circuit or short circuit, it must send the error signal. The error signal is displayed by the displayer "dual 8" (it won't display when turning off the unit, while the malfunction LED will display it). If the malfunction of temperature sensor is detected in continuous 30s, unit will turn off.

3. Buttons and Display

1) Buttons

There are ON/OFF, UP, DOWN, HEAT,COOL, FAN and FAN SPEED seven buttons in all.

In ON status, all the buttons are in valid.

- ①ON/OFF: After pressing the ON/OFF button, the unit can be switched between ON and OFF.
- ②COOL, HEAT, FAN: In ON status, after pressing the any one of the three buttons, the unit can be running in the mode you have choice; In standby mode, after pressing the MODE button, the controller will run at the running status.
- ③FAN SPEED: In ON status, after pressing the FAN SPEED button, you can select the high, medium,low and auto fan speed.
- ④UP,DOWN: Adjust the setting temperature ($60\text{--}90^\circ\text{F}$)($16\text{--}32^\circ\text{C}$) by pressing the UP and FAN SPEED buttons and you can also select other setting temperature range through configuration.

2) Dual 8 Display and LED Display

Two 8 segment nixie tube and 10 LEDs (ON/OFF, HIGH,MEDIUM, LOW, AUTO, HEAT, COOL, FAN,RESET FILTER,ENERGY SAVER).

- ①Mode LED display: when the A/C is running in a certain kind of mode, the corresponding LED is bight.
- ②ON/OFF LED: In ON status, the controller is in green color.
- ③Fan speed display: when the A/C is running at high, medium, low and auto fan speed, the corresponding LED is bright.
- ④ENERGY SAVER display:indicate the unit is operating on energy saving mode.
- ⑤RESET FILTER display:remind cleaning the filter.After cleaning,press this button to reset the filter.
- ⑥Dual 8 display: In cooling and heating mode, it is default to display the indoor ambient temperature.
On timer operation, it indicates time timing.
On failure operation,it display ERROR CODEs.

1	Indoor ambient temp sensor is open circuit and short circuit	Dual 8 displays "E2 "
2	Indoor coil temp sensor is open circuit and short circuit	Dual 8 displays "E3"
3	Outdoor coil temp sensor is open circuit and short circuit	Dual 8 displays "E5"
4	Outdoor ambient temp sensor is open circuit	Dual 8 displays "E6"

THROUGH THE WALL ROOM AIRCONDITIONER

	and short circuit	
3	Air outlet temp sensor is open circuit and short circuit/air outlet temp overheating protection in electric heating mode	Dual 8 displays "E4"
4	Defrost in cooling mode/overheating protection in heat pump mode	Dual 8 displays "E8"
5	High pressure protection	Dual 8 displays "E9"

4.Senior settings

Mode one: Fahrenheit / Centigrade display mode

When unit off,Fahrenheit and Centigrade display mode can be switched by pressing “+” and“-” at the same time for 3s.

Mode two: increase and decrease setting temperature

Press “+” once,the setting temperature will increase 1°F .When it display 90°F , it may remain this temperature regardless how many time you pressing “+”.

Press “-” once,the setting temperature will decrease 1°F .When it display 60°F , it may remain this temperature regardless how many time you pressing “-”.

Mode three: switch between 24V universal wire controller and control panel.

Press the “MODE” and “+” buttons for 5 seconds at the same time, the digital display tube will display “r” and buzzer will ring twice when it switches to 24V universal wire controller; it will display “p” and buzzer will ring once when it switches to control panel.

5. Other functions

1)power lost memory function

When repower after power lost, the controller is running according to the status before power lost.

2) energy saver

Choosing this mode,when there is no cooling demand or heating demand,the indoor fan will continue to run for a short time after compressor or electric heater off.

3) Filter cleaning reminder

When indoor motor runs for 250h accumulated, FILTER led will be lighted.After cleaning the filter, press RESET FILTER button to reset the time counting.

4)room freeze protection

Dip the dial switch 5 to ON.When indoor room temperature decreases to 50°F ,the unit will run heating mode for 3mins and when the room temperature increases to 55°F , the mode will be stopped.

V Electric Circuit Diagram

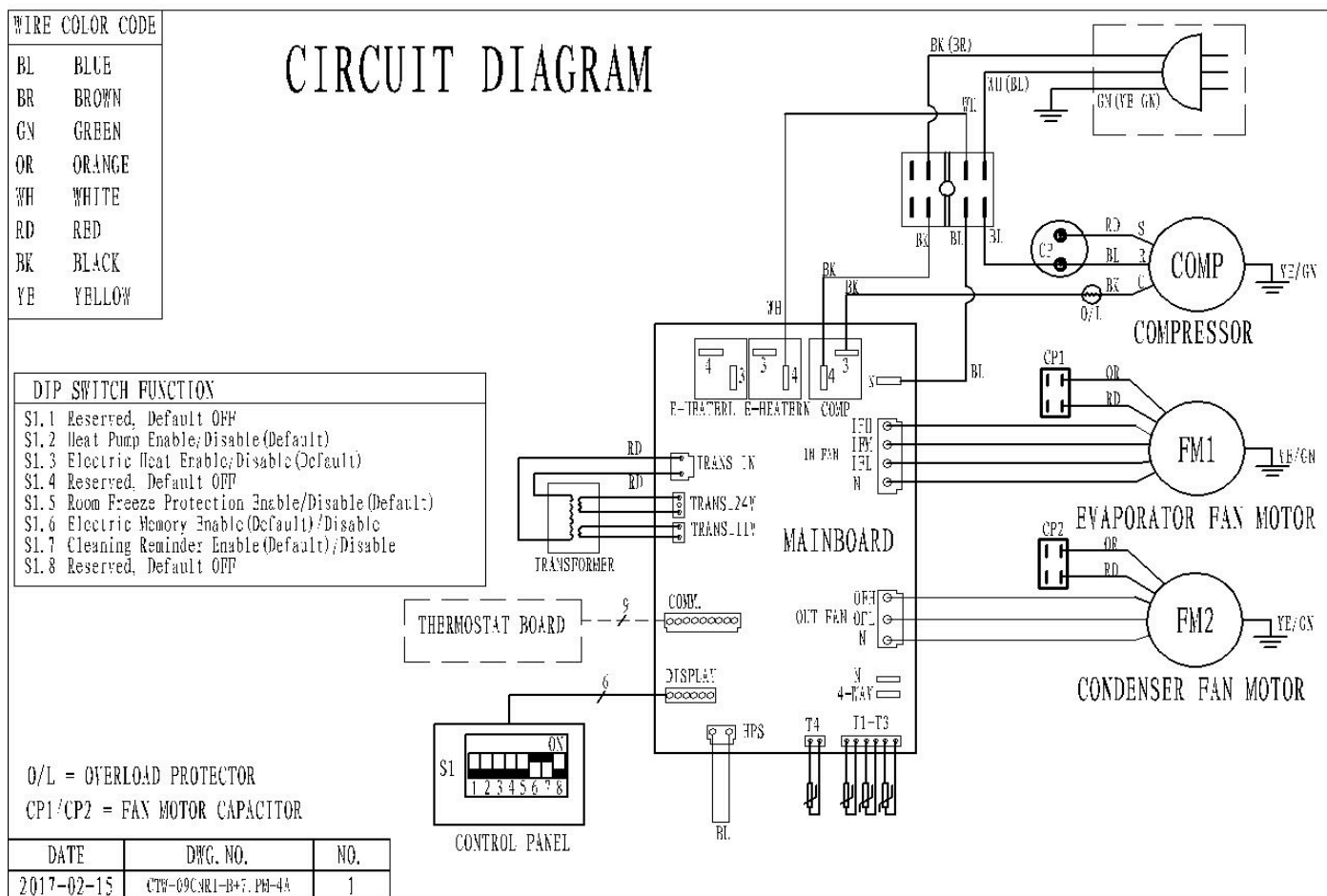

If the above electric circuit diagram has changed, please refer to it on the body

Remarks: LS agreement: It's a switching signal that when terminal "R" and "LS" close-break-close or break-close-break; five seconds is a cycle, if the switching signal appears once in one cycle, the unit will start. If the switching signal appears twice in one cycle, the unit will stop. If LS and R closing has lasted for about five second, the unit will be forced to stop. And this function can't be stored.

VII Malfunction Analysis

Malfunction	Reasons	Solve
Start Failure	power line bad, units don't have power supply	Check the voltage on the output side, push the RESET button, if still don't have voltage, but power grid has output, you need to change the

THROUGH THE WALL ROOM AIRCONDITIONER

		power line.
	Power line isn't fixed well	Check that whether power line is fixed well.
	PCB/power line fuse break	exchange the PCB fuse/power line
	Bad contact between PCB and control board	Check the contact, make sure that contact well
	Compressor delay start	It's normal, compressor will start after 3 mins
	Power cut	When power on, because of auto-restart, unit will start in 120~240s
	Power line protection trip	Check the wires that whether it comes cross plate or other metal, push the RESET button on the power line.
	Unit in protection mode	Please check the code in the manuals
	PCB or Control board is bad	Replace the PCB or control board
Control board/remote control not function	Connect wire controller, control board and remote controller, unit not function	If you need to use control board and remote controller, you need to unplug the wire controller
remote controller is not sensitive	Battery has been used for a long time; control board signal receiver is not assembled well; remote controller signal is blocked.	Replace new battery; check the signal receiver is well assembled, and no things block the remote controller.
Indoor fan/outdoor fan not function or run slowly	fan is locked by something or the connection wire is not fixed well、 fan capacitor is not fixed well; fan capacitor is out of service life.	Check that whether fan can running normal, whether motor wire is fixed well; for the slowly running speed, you could change a new capacitor.
Not well cooling/heating	Something is blocked at the indoor air outlet.	Make sure that there are not anything at the indoor air outlet.
	Something is blocked at the outdoor air outlet.	Make sure that the grill is suitable for the unit, wrong grill will cause the compressor being protected; make sure that the grill has more than 70% turnover
	Set not suitable temperature	Set higher/lower temperature by the control board, remark: temperature setting restriction will restrict the setting temperature.
	Indoor air return filter is blocked.	Should clean the filter every month at least.
	Room is hot/cold	Let unit run a little longer that room temperature will be lower/higher
	Heat leakage between indoor and outdoor	Block the leakage place
	Indoor coil not cold/heat	Charge the refrigerant

THROUGH THE WALL ROOM AIRCONDITIONER

Unit has noise	Fan blow to plate or something in the air flue	Make sure that all the fan assembly are fixed well, and nothing is in the air flue
Bad smell when heating	The dust on the E-heater is heating	The bad smell will disappear a little later
Outlet temperature is not always cooling/heating	Outlet temperature is not high enough when heating by compressor	It's normal phenomenon, it blows comfortable air when heating.
	Fan stops when cooling/heating.	It's normal phenomenon that fan stops when get to setting temperature(In new control board, could choice the different running status by the dipswitch)
Air outlet temperature is not high enough when heating.	Air outlet temperature is not high enough.	Change to E-heater mode.
Outdoor is dripping water.	Not install the drain pipe assembly.	Install the drain pipe assembly.
Indoor is dripping water.	Wall sleeve is installed incorrectly.	Install the wall sleeve according to the installation manual.
Indoor coil freeze.	Outdoor temperature is too low.	When outdoor temperature is low to 12.8°C (55 °F) or lower than this point, it will cause that indoor coil freeze, open the fresh air, and running at fan mode.
	Filter is blocked.	Clean the filter.
E2 Indoor temperature sensor failure	Indoor temperature sensor open circuit or short circuit	Check the sensor by multi-meter.
E3 Indoor coil temperature sensor failure.	Indoor coil temperature sensor open circuit or short circuit	Check the sensor by multi-meter.
E5 Outdoor coil temperature sensor failure.	Outdoor coil temperature sensor open circuit or short circuit	Check the sensor by multi-meter.
E8 Overheating protection/defrosting	Indoor fan failure/refrigerating system failure/indoor coil temperature sensor failure.	Check the indoor fan/refrigerating pipe/indoor coil sensor.
E9 High pressure protection.	Outdoor fan failure/refrigerating system failure/high pressure switch failure.	Check outdoor fan/refrigerating pipe system/high pressure switch.