

**PERFECT
COMFORT**

INSTALLATION , OPERATION AND MAINTENANCE MANUAL

Package Terminal Air Conditioner

Dual Motor Cooling With Electric Heat

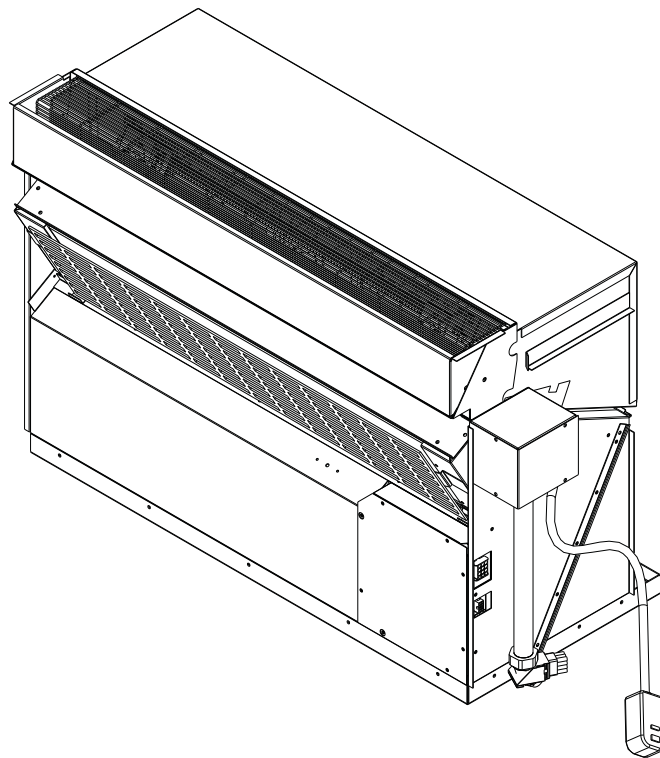

**MODEL : PCKK12K00S-T1
PCKK15K00S-T1**

CONTENTS

1. Read this first	1
To the installer	1
General precautions	2
2. Check list	3
3. General Product Information	4
Product description	4
Standard controls and Components	5
Controls and Feature	5
Mode coding	6
4. Preparing for the installation	7
Electrical Supply	7
Electrical short hazard	7
Remove the old chassis	7
Check existing sleeve	7
Check existing outdoor louver	7
5. Installation instruction	8
Installation of sleeve	8
Installation of fan blower assy	8
Installation of cooling chassis	9
Electric beater size selection	9
Wiring harness connection to cooling chassis	10
Wall thermostat installation	10
Installation of room cabinet	11
6. Final Inspection and start-up	12
Final check list	12
Start-up	12
Wall thermostat	12
7. Maintenance and Troubleshooting	13
Monthly inspection and maintenance	13
Seasonal Start-up and maintenance	13
Troubleshooting	15
8. Performance Data	20
9. Warranty	21

TO THE INSTALLER

Retain this manual for future reference.

Before leaving the premises, review this manual to be sure the unit has been installed correctly and run the unit for one complete cycle to make sure it functions properly.

To obtain technical service or warranty assistance during or after the installation of this unit, contact your local representative. For further assistance please **call +1-866-233-4022**

When calling for assistance, please have the following information ready:

Model number:

Serial number:

Date of installation:

NOTICE

Due to ongoing product development, product designs and specifications may change without notice. Pls contact the factory for more information.

WARNING

Electric shock hazard

Turn off electric power before service or installation.

Don't use this unit if it has damaged wiring, is not working properly, or has been damaged or dropped.

Read these instructions carefully and completely before attempting installation. Unit should be installed by qualified service personnel **ONLY**

Failure to do so can result in property damage, personal injury and/or death.

DANGER

WIRE SIZE: Use **ONLY** wiring size recommended for single outlet branch circuit.

FUSE/CIRCUIT BREAKER: Use **ONLY** type and size fuse or HACR circuit breaker indicated on Receptacles and Fuse Type(see Table 01). Proper current protection to the unit is the responsibility of the owner.

GROUNDING: Unit **MUST** be grounded from branch circuit through service cord to unit, or through separate ground wire provided on permanently connected units. Be sure that branch circuit or general purpose outlet is grounded.

Do not modify the PERFECT COMFORT replacement PTAC POWER CORD

The power cord should be checked before every use. Do not use the product if the cord fail the test.





A damaged power cord must be replaced with a new cord from the manufacturer and not repaired.

The use of extension cords is prohibited.

RECEPTACLE: The field supplied outlet must match plug on service cord and be within reach of service cord. Refer to TABLE 01 for proper receptacle and fuse type

Failure to follow these instructions can result in a fire, explosion or electrical shock, causing property damage, personal injury or death

Table 01: Receptacles and Fuse Types

Table 1	250V			265/277V
AMPS	15	20*	30	20
RECEPTACLE				
TIME-DELAY TYPE FUSE (or HACR circuit breaker)	15	20	30	20

HACR — Heating, Air Conditioning, Refrigeration
 *May be used for 15 Amp applications if fused for 15 Amp
NOTE: 265/277-volt units require use of accessory subbase DAX99SB to meet NEC and local codes.

CAUTION

Sheet metal parts, self-tapping screws, clips and such items inherently have sharp edges, and it is necessary that the installer exercise caution.
 This equipment is to be installed only by an experienced installation company which employs trained personnel.
 PTAC chassis are heavy. To avoid injury, use assistance when lifting.

CHECK LIST

When the equipment is received, all items should be carefully checked refer to typical configuration(see Fig.01). All units should be carefully inspected for damage when received. If any damage is noticed, the carrier should make the proper notation on the delivery receipt acknowledging the damage.
 Pls call: **+1-866-233-4022** for customs service

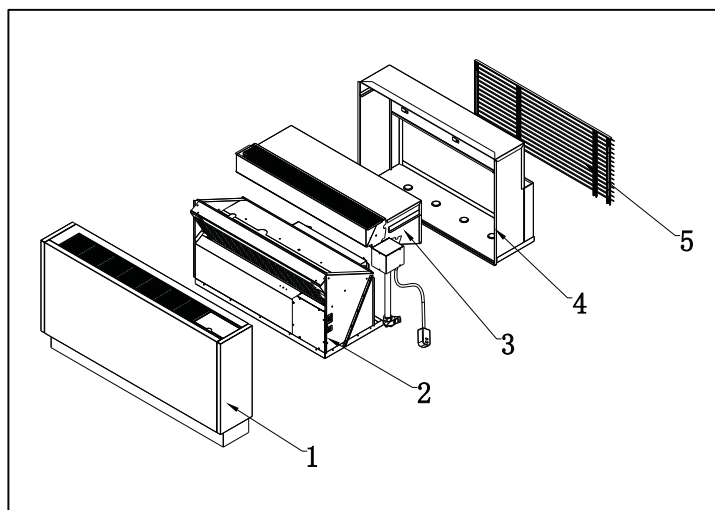

Fig.01: Typical Configuration

1. Room Cabinet
Verify the room cabinet in good condition, no deformation or damaged.
2. Cooling Chassis
The unit nameplate should be checked to make sure the voltage agrees with the power supply available. Make sure correct chassis has been received(as well as any option)
Verify your equipment by using “Model coding” on page 6.

Verify that indoor blower wheels and outdoor fan blades are secured to their motor shafts and rotate freely.
Verify the compressor and tubing in proper position and perfect status.

3. Fan Blower Assy

Check if the assy matchas the cooling chassis.

4. Sleeve

The sleeve should be checked the outline dimension match the existing hole

The opening of the existing hole should be 36 1/2" width, and 14 1/2" height.

5. Louver

The Louver should be checked the dimension , and make sure match the sleeve.

ACCESSORY:

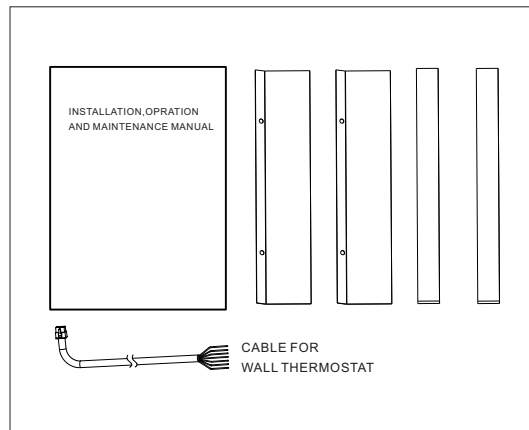

This replacement PTAC, only item 2, 3 are provided

GENERAL PRODUCT INFORMATION

Product description

PERFECT COMFORT replacement Package Terminal Air conditioner are cooling chassis with electric heat.

The **PERFECT COMFORT** PTAC unit:

1. Use R410A refrigerant. This refrigerant is not affected by a phase out schedule. R410 is environment friendly.
2. Include high-efficiency rotary compressors protected by a 5-year warranty
3. Offer three speed for evaporator fan motor, and one speed for condenser fan motor
4. Dual motor system
5. Condensate removal system with single drain hose, re-evaporation to improve efficiency
6. Dual centrifugal cross fan make the unit operate quietly

Standard control and components

Construction

1. 18 gauge galvanized steel and powder-coated for base pan and bulkhead, 20gauge galvanized steel and powder-coat for construction.
2. Dual centrifugal evaporator fan with galvanized steel
3. Plastic fan blades for condenser
4. 20gauge galvanized steel and powder coated for drain pan
5. Motors are thermally-protected .
6. Air stream surfaced are insulated with 3/16 PE
7. Washable filter

Condensate remove system

1. Single drain hose lead the condensate to outside base pan.
2. Slinger ring of plastic fan blades throw the condensate to the condenser coil, where it evaporates, improving system performance.

Controls

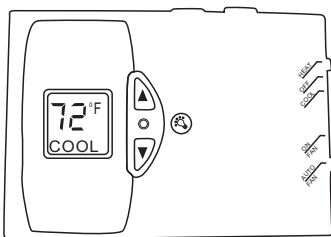

Wall thermostat

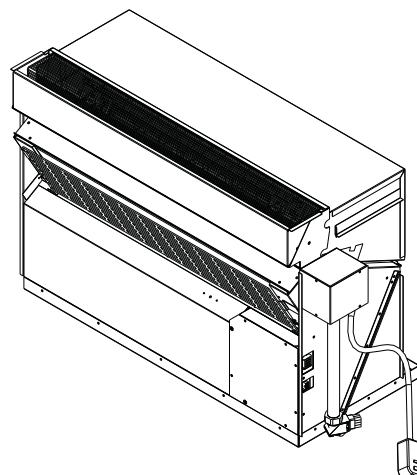
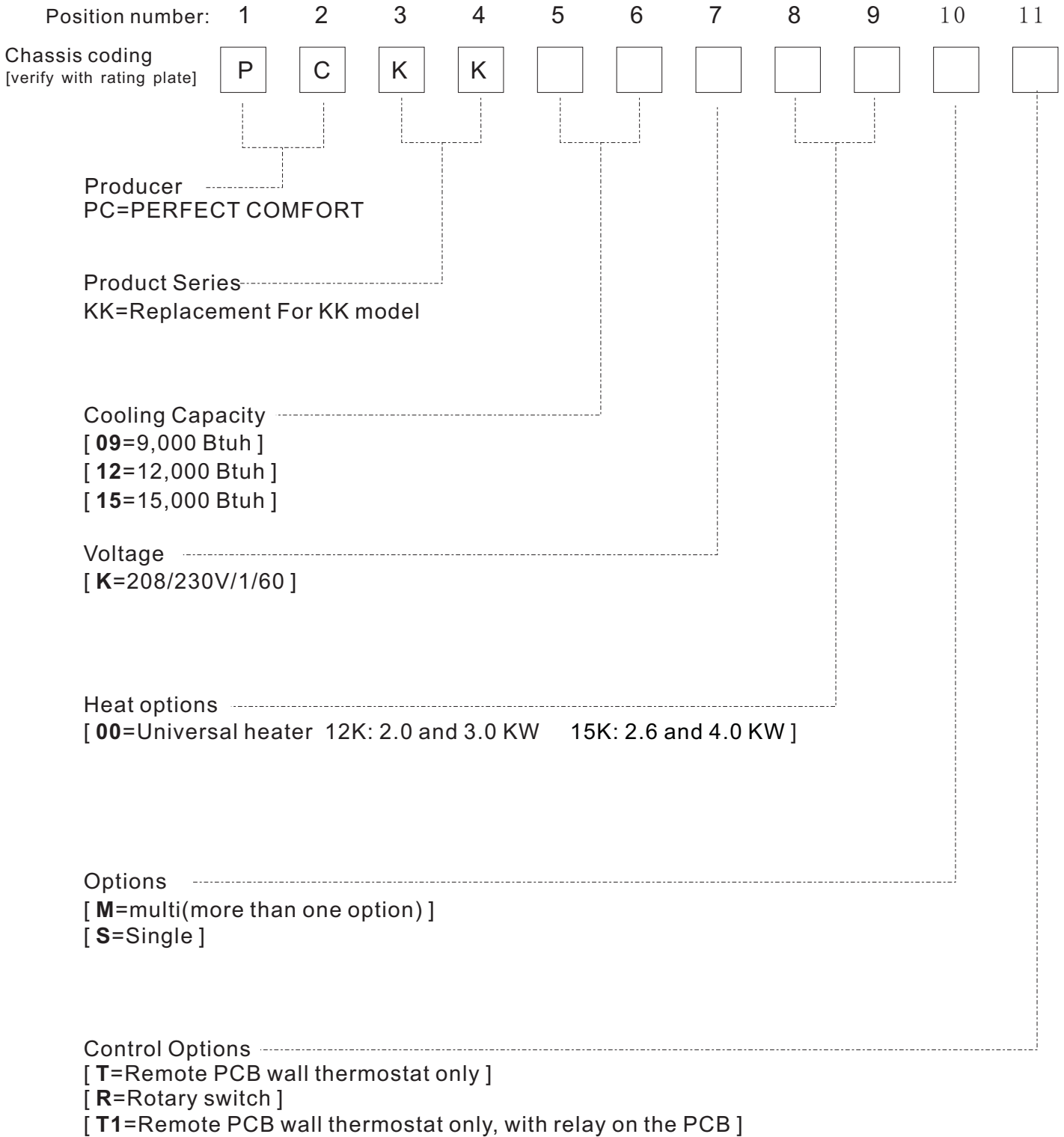

Fig.02: Controls

MODEL CODING

Model Coding



PREPARING FOR THE INSTALLATION

WARNING

Moving parts can cause personal injury. Avoid contact with moving parts when testing or servicing the unit.

Electrical supply

Each unit must have a separate branch circuit protected by a fuse or breaker. Refer to the unit rating plate for the proper wire and breaker or fuse size

Use of extension cords is prohibited

DO NOT connect the **PERFECT COMFORT** unit to a circuit with an incorrectly-sized overcurrent-protection device

Electrical short hazard

Before opening the existing unit:

Open the power supply disconnect switch. Secure it in an open position during installation. Attach a sign stating, "DO NOT TURN ON"

On a plug and receptacle connection, unplug the existing unit at the wall outlet.

DO NOT plug in the new unit until installation is complete and the start-up check list has been completed.

Failure to comply with the above could result in severe personal injury, death or substantial property damage.

Remove the old chassis

1. Disconnect power or unplug cord before proceeding
2. Remove the room cabinet to expose the old chassis.
3. Loosen any tie-down bolts or screws and remove the old chassis

Check existing wall sleeve

PERFERCT COMFORT replacement PTAC are to be used with metal wall sleeve:

- a. Clean the wall sleeve of any dirt
- b. Repair any damage and rust
- c. Ensure proper drainage of condensate or rainwater to exterior of building
- d. Check the back of sleeve is pitched to the outside by ½ inch max
- e. Check the sleeve is level left to right
- f. Make sure the wall sleeve secured in the wall

Check existing outdoor louver

Check whether the type of the outdoor louver match the baffle and insulation on the chassis, adjust if it doesn't match.

Remove any obstructions

INSTALLATION INSTRUCTION

INSTALLATION OF SLEEVE(NOT NECESSARY FOE REPLACEMENT UNIT)

- 1.Instal the sleeve in the wall.
- 2.Put the grille through the wall, and fix it to sleeve with four screws.

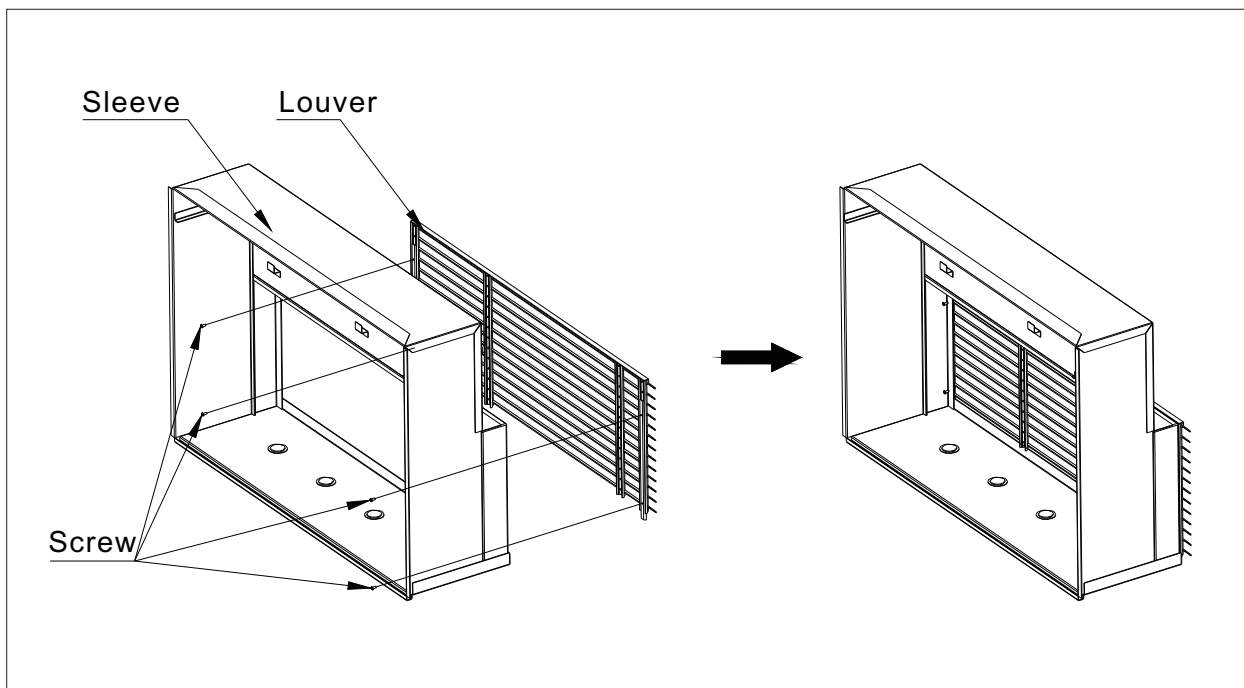

Fig.03 Installation of sleeve

INSTALLATION OF FAN BLOWER ASSY

- 1.Lift the fan blower assy and make its supporting strips(left and right) to the rails of the sleeve.
- 2.Slide it in until it is fixed properly.

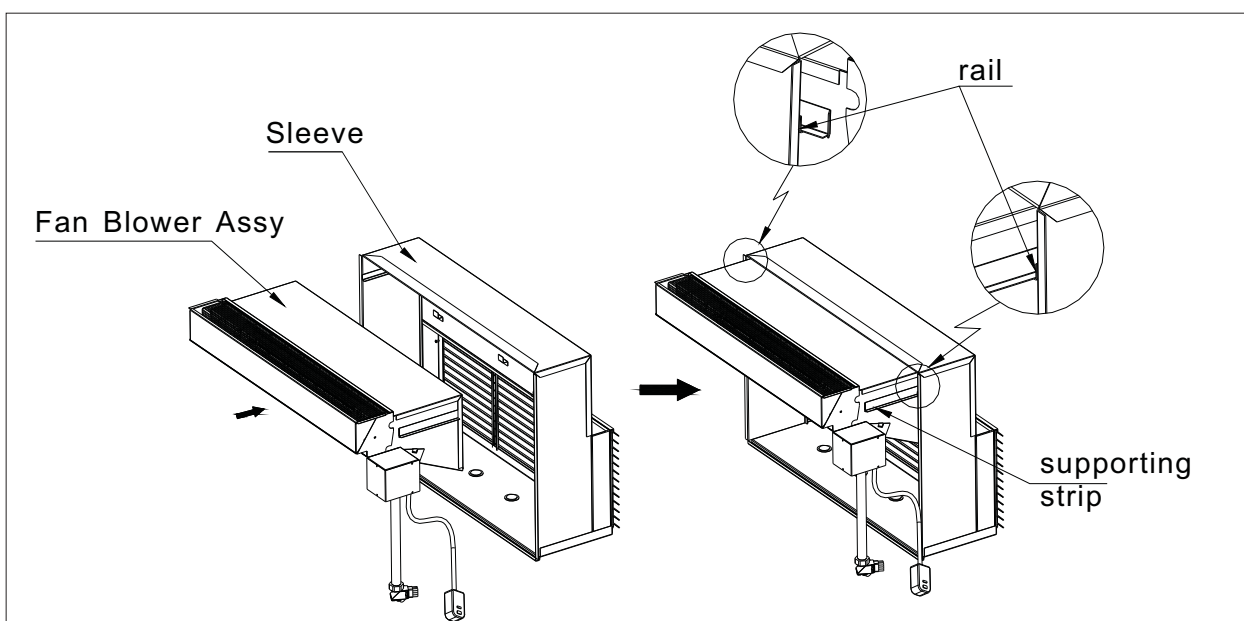

Fig.04 Installation of fan blower assy

INSTALLATION OF COOLING CHASSIS

1. Cooling chassis is level to the sleeve symmetrically.
2. Slide it steadily into the sleeve until it is properly fixed.

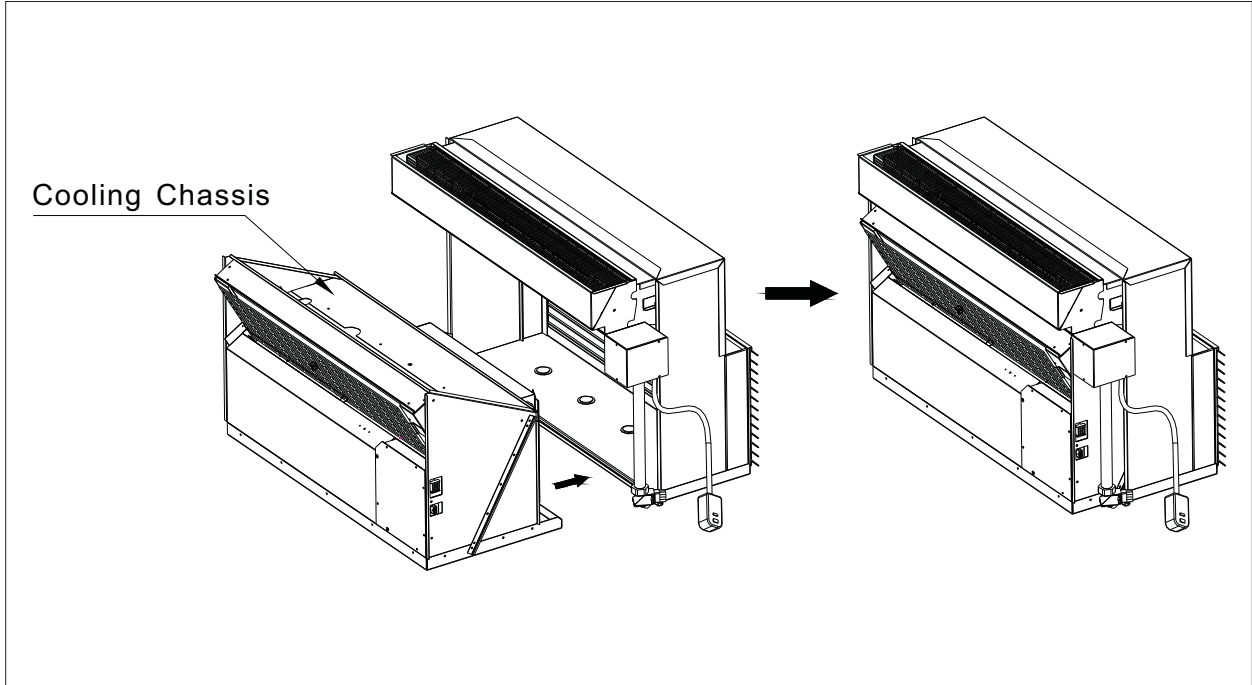

Fig.05 Installation fo cooling chassis

ELECTRIC HEATER SIZE SELECTION

1. Remove junction box cover by moving four screws. See Fig.06
2. Choose electric heater size as your requirement.

Pay attention—Different electric heater size requires different cable connection.

See TABLE 02-CABLE CONNECTION CHART

3. Reinstall junction box cover.

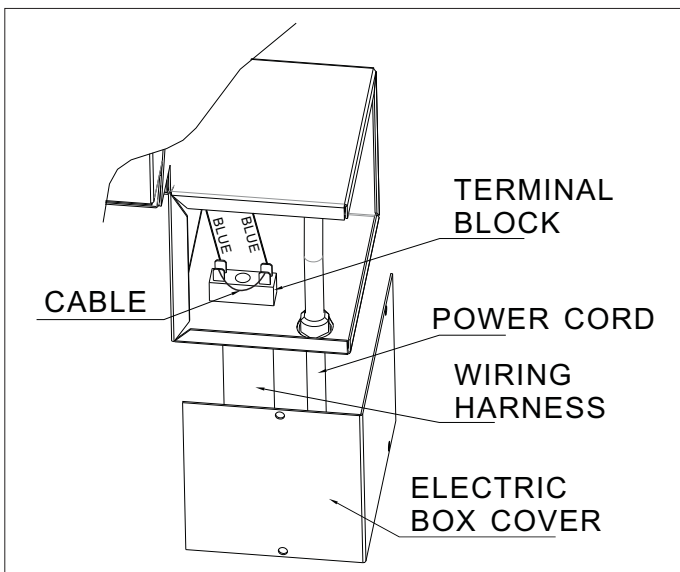

Fig.06 CABLE CONNECTION

TABLE 2-CABLE CONNECTION CHART

UNIT MODEL		CABLE
PCKK12K 00S-T1	2.0 KW	×
	3.0 KW	✓
PCKK15K 00S-T1	2.6 KW	×
	4.0 KW	✓
×		Disconnection
✓		Connection

WIRING HARNESS CONNECTION TO COOLING CHASSIS

Connect the wiring harness of fan blower assy to the cooling chassis(as Fig.07), until it is fixed properly.

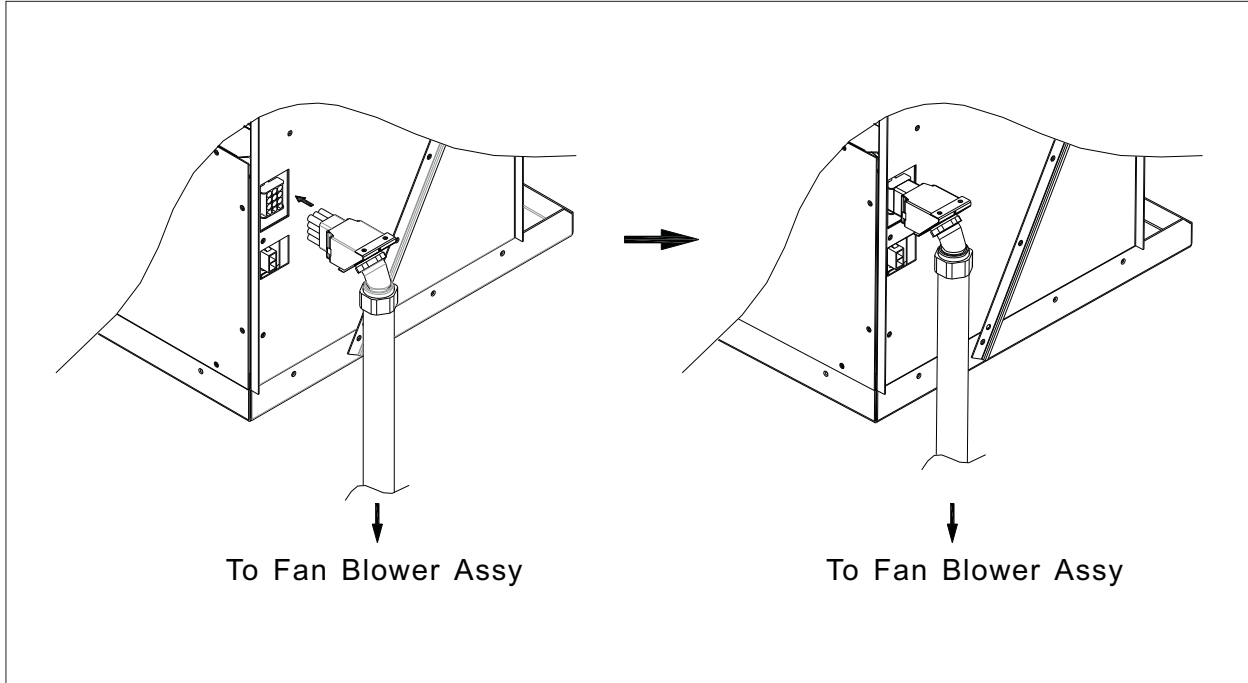

Fig.07 CABLE CONNECTION

WALL THERMOSTAT INSTALLATION

Connect the wall thermostat cable with the chassis as Fig.08

Install the wall thermostat as per the detail separate manual for wall thermostat installation,

Connect cable from chassis to the existing wires in the wall as Fig.08

Ensure to wrap and make protection at the joint points.

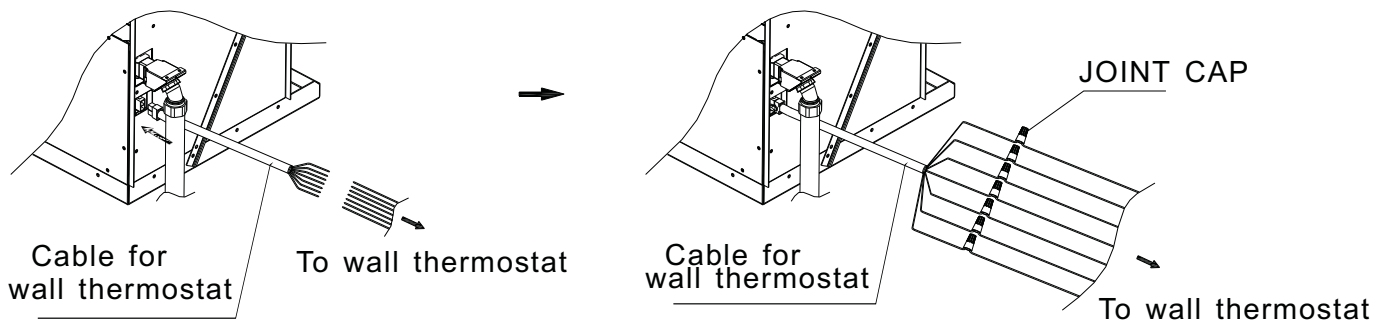

Fig.08 CABLE CONNECTION FOR WALL THERMOSTAT

INSTALLATION OF ROOM CABINET

Cover the unit with the cabinet. Make the air outlet of the cabinet towards that of fan blower. Ensure it is fixed properly.

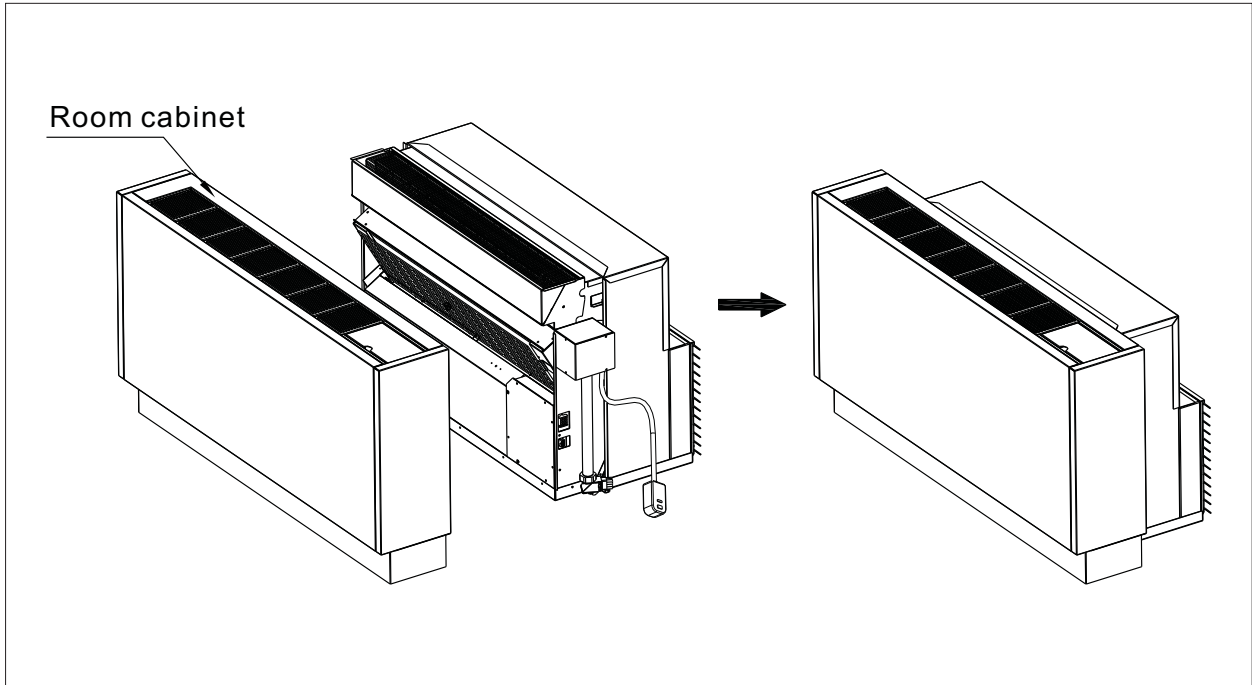

Fig.09 Installation of room cabinet

FINAL INSTALLATION SECTION VIEW

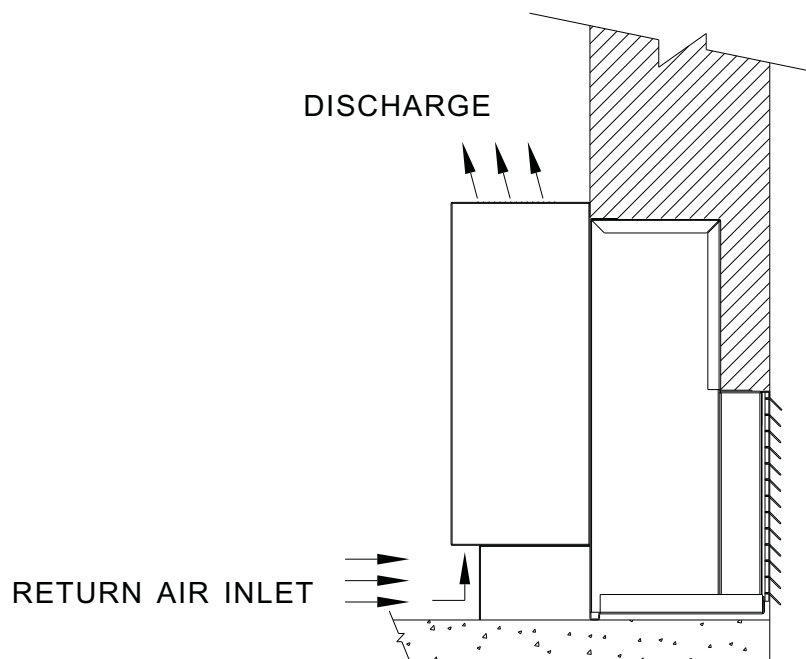

Fig 10.

FINAL INSPECTION AND START-UP

Check list

- . Ensure the chassis is secured with the sleeve
- . Unit is installed in compliance with all codes
- . Circuit breakers and wire sizes are correct.
- . Ensure the electrical supply matches the electrical requirements of the unit, and that the unit is properly grounded.
- . Check whether the electric heat match the power cord
- . Filter clean and in place
- . All panels in place
- . Make sure the chassis is level
- . Verify that nothing will interfere with the room discharge air or the return air of the units. Examples:
 - . Check for curtains or drapes that obstruct the air flow.
 - . Check for plus carpeting that can obstruct the return air
 - . Items like these can cause serious damage to the chassis.
 - . Ensure work area clean and free of debris

Start-up

- . Plug the power cord to the receptacle
- . Turn on the chassis, and operate all functions:

WALL THERMOSTAT

- . Push the mode switch to either positions (see Fig. 11) : Cool-off-Heat
- . Push the Fan switch to either positions (see Fig. 11) : On Fan-Auto Fan
- . Press the UP key to increase the temperature, or press the DOWN key to decrease the temperature (see Fig. 11)
- . Press the light bulb button to illuminate the display. Adjusting the temperature will keep the display lit until no button has been pressed for over ten seconds.

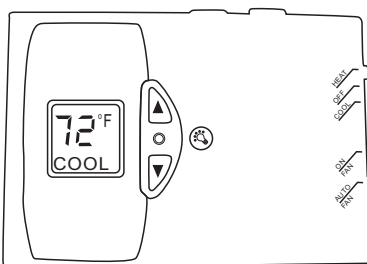

Fig 11. Wall thermostat

- COOL-Work in cool mode
- OFF-The chassis is at off status
- HEAT-Work in heat mode
- ON FAN-Fan runs continuously even without heating or cooling
- AUTO FAN-Fan runs automatically during heating and cooling.

MAINTENANCE AND TROUBLESHOOTING**Monthly inspection and maintenance**** DANGER**

Electrical shock hazard-Disconnect power to the PERFECT COMFORT replacement PTAC before servicing or accessing the control compartment. Failure to do so could result in severe personal injury or death.

 WARNING

It is illegal to discharge refrigerant into the atmosphere. Use proper reclaiming methods and equipment when servicing a **PERFECT COMFORT** replacement PTAC.

For optimum performance and reliability of your PERFECT COMFORT replacement PTAC, PERFECT COMFORT recommends performing the following inspections and maintenance on a monthly basis. Units that are installed in harsh or dirty environments will require more frequent inspections and maintenance.

- Clean or replace the indoor air filter.
- Vacuum return air grille surface.
- Inspect & clean the chassis interior for rodent or insect infestation.
- Clean & flush condensate drain pan and chassis base pan.
- If applicable, ensure the condensate drain is functioning properly.
- Inspect refrigeration tubing, especially braze joints, for signs of refrigerant leaks (*oil residue*). Repair if necessary.
- Inspect indoor and outdoor coils. Ensure dirt or debris have not collected on the fins. Clean if necessary. Be careful not to damage coil fins when cleaning. Use a fin comb to straighten any bent fins.
- Examine control box. Ensure all wire connections are secure.
- Ensure indoor blower wheels and outdoor fan blades are secured to their motor shafts.
- Ensure dirt or debris have not collected on the indoor blower wheels and outdoor fan blades. Use a vacuum and soft brush to clean if necessary.
- Clean the exterior of the cabinet as desired with a mild soap or household cleaner.
- 5 KW heat models only**-in the event the limit switch opens and de-energizes the electric heat, the limit switch will need to be manually reset.

 WARNING

Clean or replace the return air filter as needed, Allowing dust to collect on the filter will cause the unit to lose efficiency and eventually malfunction. Check the filter at least once a month. Some environments may require more frequent replacement, depending on particulate in the air stream.

NOTICE

If a new air filter is needed for your **PERFECT COMFORT** replacement PTAC, consult supplier for availability and/or proper sizing.

SEASONAL START-UP AND MAINTENANCE

At the beginning of the cooling and heating seasons, a complete mechanical check should be performed and maintenance/ inspections performed as described below.

Disconnect power to unit and remove necessary access panels.

1. Performing the inspections and maintenance defined in "Monthly start-up and maintenance."

2. Do a visual check of the equipment. Look for obvious changes in the unit such as damaged coils or evidence of extended wear on any moving parts.
3. Check for unusual odors, oil leaks, or stains on or around the coil and refrigerant lines. The presence of oil here may indicate a potentially serious problem such as a refrigerant leak.
4. Make sure the base pan is clean.
5. Inspect all electrical connections. Look for frayed wires and poor connections. Terminal ends that are loose will eventually fail, causing a loss of performance or worse.
6. Check fan motors and blower assemblies. Some units may require a drop of light oil to motors and/ or bearing assemblies (*look for oil cups*). Ensure setscrews and motor mounting hardware are tight.
7. Brush and/or vacuum the centrifugal fan blades and blower cage assemblies, as they must be clean to operate efficiently.
8. Inspect both indoor and outdoor coils. Use a fin comb to straighten out any damaged fins. These coils must be clean for proper operation.

WARNING :Do not use a solvent-based cleaner to clean coils, as some solvents will produce a noxious odor when the unit is in operation.

9. Inspect and clean the drain pan and drain line(s). The use of an anti-fungicide tablet to keep the condensate system free from bacterial contaminants is recommended.
10. Check the pitch of the unit. Over time the building and equipment may settle, causing a shift in the direction of the condensate flows. Ideally the unit should pitch a minimum of 5 (at least 1/2") to the outside to allow for proper drainage.
11. Check drainage holes along rear flange of the base pan to ensure they are free of debris.
12. Check to ensure the seal around the unit is not broken or damaged.

NOTICE :Air leaks may make the conditioned area uncomfortably drafty or produce noises. Visually inspect the foam gasket between the wall and the unit, especially taking note of the separation between the air inlet for the condenser and the condenser coil discharge. These two areas must be sealed off from each other. If you experience poor cooling operation or erratic operation, check for air recirculation at the condenser coil.

14. Replace the access panels and reconnect the electrical power.
15. Test the unit operation.

TROUBLESHOOTING GUIDE

SYMPTOM	CAUSE	CHECK/CORRECTION
<p>Thermostat does not Properly Control Room Temperature, Runs Continuously, or Causes Abnormal Cycles in Heating or Cooling Mode</p>	<p>Sleeve seals worn or missing allowing outdoor air to be passed over the thermostat sensing bulb.</p> <p>Defective thermostat.</p> <p>Thermostat bulb/sensor not properly located.</p> <p>Thermostat/sensor temperature limiting option not set up properly.</p>	<p>Inspect and replace if necessary.</p> <p>Test and replace if necessary.</p> <p>Ensure bulb is clipped to evaporator coil at original factory specified location.</p> <p>Set up the temperature limiting option according to the unit Installation Instructions.</p>
<p>Compressor Short Cycles</p>	<p>Low voltage.</p> <p>Restricted condenser air.</p> <p>Recycling of condenser air.</p> <p>Condenser fan motor operating intermittently, rotating slowly, or not at all.</p> <p>Thermostat bulb/sensor not properly located.</p> <p>Faulty or incorrect compressor overload.</p> <p>Indoor coil freezing.</p> <p>Recycling of indoor air.</p>	<p>Check voltage with unit running and ensure it is within nameplate limits.</p> <p>Check for dirt or other condenser coil restriction. Clean as necessary.</p> <p>Check for inadequate discharge air installation clearances. Coil not sealed against grille, Unit may not be completely pushed into sleeve.</p> <p>Check to see if fan or shaft is being rubbed or experiencing external friction, Check free rotation of the motor shaft. Check voltage to the motor. Check motor capacitor. Check for miswiring. Motor may be seizing internally. Motor have open windings, or internal overload is defective - if so, replace motor.</p> <p>Ensure bulb is clipped to evaporator coil at original factory specified location.</p> <p>Check for correct overload model number and replace if incorrect. Otherwise, if running amps seem normal, replace overload.</p> <p>See "Evaporator Coil Frosts".</p> <p>Ensure that curtains or other obstructions are not short circulating air between the outlet grille and return air intake.</p>

TROUBLESHOOTING GUIDE

SYMPTOM	CAUSE	CHECK/CORRECTION
Compressor Short Cycles (continued)	Compressor running too slow and drawing high amps.	Compressor may be miswired. Check capacitor. Compressor may be seizing - if so, replace compressor.
Compressor Will Not Run	Fuse or circuit breaker tripped.	Replace or reset as necessary.
	Defective switch.	Test and replace if necessary.
	Defective thermostat./sensor	Test and replace if necessary.
	Indoor room temperature below thermostat set point.	Lower thermostat setting if comfort not yet achieved.
	Indoor room temperature below 65°F	Cooling will not operate if the room temperature is below 65°F.
	Outdoor temperature too cold.	Compressor is not intended to operate at cold outdoor temperatures.
	Broken, shorted, loose or miswired wiring.	Inspect and correct.
	Defective compressor capacitor.	Test and replace if necessary.
	Defective compressor overload.	Test and replace if necessary.
	Low voltage or no voltage to compressor.	Check voltage and ensure it is within nameplate limits.
	Compressor windings open.	Disconnect overload from compressor terminals. Check for winding resistance across all winding pairs C-S, C-R, S-R and check each terminal to the compressor shell for ground faults. Replace compressor if any windings are open-circuited or short circuited to the shell.

TROUBLESHOOTING GUIDE

SYMPTOM	CAUSE	CHECK/CORRECTION
Compressor Will Not Run (continued)	Seized compressor.	If all of the above check out OK and if pressures are equalized, and compressor draws high amps and will not start, compressor is seized and needs to be replaced.
Unit Trips Fuse / Circuit Breaker	Shorted or incorrect wiring.	Check all connections. Also check for shorts within devices such as motors, switches, heater etc..
	Shorted capacitor.	Test and replace if necessary.
	Compressor short cycling.	See "Compressor Short Cycles".
	Power was interrupted to the unit.	Wait 3 minutes before restarting.
	Fuse or breaker setting too low.	Check nameplate fuse size.
	Broken, shorted, loose, or miswired wiring.	Inspect and correct.
	Low voltage or no voltage.	Check voltage with unit running and ensure it is within nameplate limits.
	Seized or slow running compressor.	See above.
Evaporator Coil Frosts	Dirty air filter.	Clean or replace.
	Dirty evaporator coil.	Clean as necessary.
	Blower motor operating intermittently, rotating slowly, or not at all.	Check to see if blower wheel or shaft is being rubbed or experiencing external friction. Check free rotation of the motor shaft. Check voltage to the motor. Check motor capacitor. Check for miswiring. Motor may be seizing. Motor may have open windings, or internal overload is defective - if so, replace motor.

TROUBLESHOOTING GUIDE

**PERFECT
COMFORT**

SYMPTOM	CAUSE	CHECK/CORRECTION
Evaporator Coil Frosts (continued)	Low refrigerant charge.	Look for telltale signs of low charge. For example, check the frosting pattern starting from a defrosted condition. If the whole evaporator face frosts uniformly at the same time, it indicates that the unit has insufficient indoor airflow. If the frost work its way up the face of the evaporator during operation over time, it indicates low charge. Low running amps, low or no subcooling, and excessive superheat are other signs of undercharge. Find and fix the leak and recharge R22 to the nameplate charge.
	Faulty thermostat.	Test and replace if necessary.
Unit Rattles or is Noisy	Defective compressor.	Check and replace if necessary.
	Refrigerant line hitting surroundings.	Bend tube slightly to obtain clearance.
	Loose fan, blower, or motor mounts .	Check and tighten if necessary.
	Rubbing of fan or blower on housing.	Ascertain cause and correct. Check during operation.
No Heating	Faulty thermostat.	Test and replace if necessary.
	Fuse or circuit breaker tripped.	Replace or reset as necessary.
	Cord not plugged in.	Plug in.
	Defective switch.	Test and replace if necessary.
	Defective heater.	Inspect and replace if necessary.
	One-time thermal fuse is blown.	Check thermal fuse for open circuit and replace if necessary.
	Automatic reset high limit control will not reset.	Check high limit for open circuit and replace if necessary.

TROUBLESHOOTING GUIDE

SYMPTOM	CAUSE	CHECK/CORRECTION
No Heating (continued)	Broken, shorted, loose, or miswired wiring.	Inspect and correct.
Heater Output Intermittent or Insufficient	Indoor room temperature above thermostat set point.	Raise thermostat setting if comfort not yet achieved.
	Faulty thermostat.	Test and replace if necessary.
	Automatic reset high limit control calibration defective.	Replace high limit.
	Dirty air filter.	Clean or replace.
	Dirty evaporator coil.	Clean as necessary.
Water Drips from Unit	Blower motor operating intermittently, rotating slowly, or not at all.	Check to see if blower wheel or shaft is being rubbed or experiencing external friction. Check free rotation of the motor shaft. Check voltage to the motor. Check motor capacitor. Check for miswiring. Motor may be seizing internally or internal overload is defective - if so, replace motor.
	Sleeve not properly mounted.	Check sleeve for the required 3/8" pitch down from indoor to outdoor side and level side-to-side. Readjust as required.
	Condensate drain plugged.	Clean condensate drain spout passing through the dividing wall.
	Evaporator drain pan cracked or improperly mounted.	Inspect, realign or replace plastic drain pan as required.
	Unusually high moisture content in the indoor and/or outdoor air.	Under certain ambient conditions excessive condensate can be generated, beyond the capacity for the unit to reject via evaporation to the outdoor air stream. If objectionable or frequent, connect to an internal drain system with available optional drain kit.
	Drain holes plugged in bottom edge of sleeve on outdoor side.	Inspect and clear blockage.

PCKK Specification

Model	Cooling		Sensible heat Ratio	EER	Electric Heat			Indoor Air Flow CFM		shipping weight	shipping box dimension	Chassis dimension
	Btuh(kw)				Btuh(kw)	Hi	Medium	Low	lbs(kg)			
PCKK12K00S-T1	12000(3.5)	0.69	8.9	10236(3.0) 6824(2.0)	337	294	230	FAN	57(26)	1065x370x450	904x375x275	
												MAIN
PCKK15K00S-T1	15000(4.4)	0.66	8.4	13650(4.0) 8900(2.6)	337	294	230	FAN	57(26)	1065x370x450	904x375x275	
												MAIN

PCKK - 12,000BTU electrical specifications

Power Supply volt—1-60		Compressor		Indoor Fan Motor		Outdoor Fan Motor		Electric Heat				Unit Electrical Ratings				
Volt	Min	RLA	LRA	FLA	Hp	ELA	Hp	Htr#	Volt	W	HA	A/ Cooling	A/ Heating	MAX.A	MAX HACK BRKR	Plug
208/ 230V	197	5.43	27	0.532	0.15	0.56	0.2	2	230	2000	8.7	6.5	10.5	21	25	6-30P
								3	230	3000	13					

PCKK - 15,000BTU electrical specifications

Power Supply volt—1-60		Compressor		Indoor Fan Motor		Outdoor Fan Motor		Electric Heat				Unit Electrical Ratings				
Volt	Min	RLA	LRA	FLA	Hp	ELA	Hp	Htr#	Volt	W	HA	A/ Cooling	A/ Heating	MAX.A	MAX HACK BRKR	Plug
208/ 230V	197	6.6	32.6	0.532	0.15	0.56	0.2	2	230	2600	11.6	8.1	12.2	21	25	6-30P
								3	230	4000	17.4					

**PERFECT COMFORT PACKAGED TERMINAL AIR CONDITIONER
WARRANTY FOR PRODUCTS PURCHASED AND USED
IN CANADA & USA**

SAVE THIS CERTIFICATE.

BEFORE CALLING FOR SERVICE, carefully read your instruction booklet. In the event your air conditioner requires servicing contact you're nearest authorized service centre. If you do not know the nearest service centre, ask the company that you bought your air conditioner from or contact us. When requesting service, please have the model number, serial number, and date of purchase and a description of the problem available. Service will be provided during normal working hours.

ESTABLISHING PROOF OF PURCHASE DATE for warranty purposes is the customer's responsibility failing which the effective date will be based upon the date of manufacture plus thirty (30) days. Retain your bill of sale as proof of purchase.

STANDARD LIMITED ONE YEAR WARRANTY

We will supply a replacement for any component part(s) found to be defective in materials or workmanship. Any replacement part(s) so supplied will be warranted for the balance of our product's warranty. We will pay for labor costs for such repair work at our established labor rates. See labor warranty sheet and rates for labor allowance. No payments will be made without an NRG approval number. All approval numbers are issued prior to doing any warranty work.

EXTENDED PARTS WARRANTY

In the second through fifth year of warranty from the date of original purchase, if the compressor is found to be defective, we will supply a replacement part only. All replacement compressors assume the unused portion of the original warranty.

USER WILL PAY FOR SERVICE CALLS TO:

- Instruct the user on how to use the air conditioner.
- Replace house fuses, reset circuit breakers or correct house wiring.
- Clean or replace air filters.
- Correct improper installations.
- All expenses where the air conditioner is subjected to improper installation, inadequate maintenance, abuse or misuse, neglect, accident, fire, flood, or incorrect power source.
- The removal and reinstallation of the air conditioner if it is installed in an overhead or other inaccessible location.
- Shipping charges to deliver the air conditioner to an authorized service depot and return to installation.
- All labor and service call charges incurred after the Standard Limited One Year Warranty have expired, including diagnosis of the problem to accomplish repair.
- Cost of replacement refrigerant and all other charges incurred after the Standard Limited One Year Warranty has expired.

Service must be provided by a PERFECT COMFORT authorized service depot. All service calls and labor charges will be at our rate in effect at the time of the service.

This warranty applies only while the air conditioner remains at the original site and only to air conditioners installed in Canada & USA. PERFECT COMFORT or its affiliates shall not be liable for any indirect, incidental, consequential, or special damages in connection with any use or failure of this air conditioner. No one is authorized to change this warranty or to create for us on our behalf any other obligation or liability in connection with our product(s). There is no other warranty or condition in any respect, expressed or implied, made by or binding upon us other than the above or as provided by provincial law and which cannot be limited or excluded by such law.