

GENUINE COMFORT

DELIVERING COMFORT CONSISTENTLY

www.genuinecomfort.com

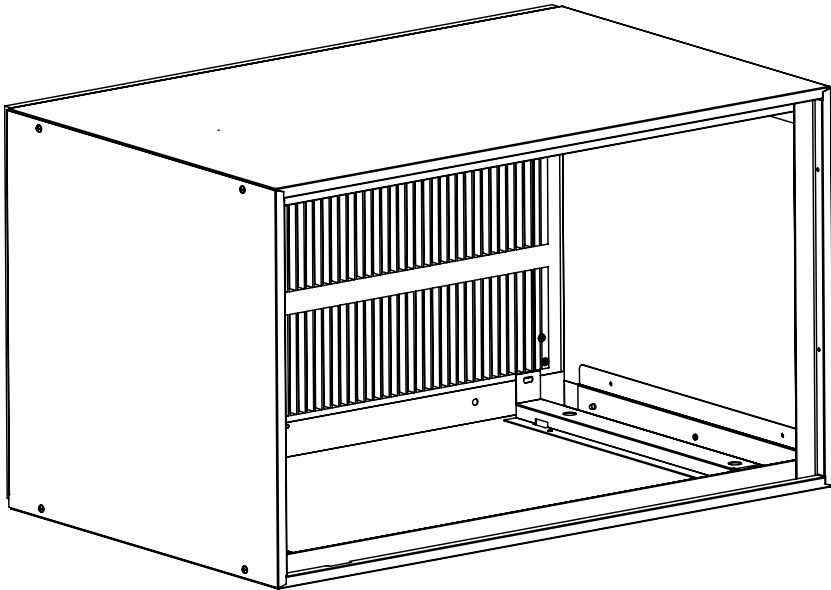

General Information

The wall sleeve must be installed before the air conditioner chassis can be set in place. Read the instructions thoroughly before proceeding.

Table of Contents

General Information	1
Assemble the Wall Sleeve	2
Preinstallation Considerations	3
Wall Sleeve Installation	4



RECOGNIZE THIS SYMBOL AS A SAFETY PRECAUTION.

ATTENTION INSTALLING PERSONNEL

As a professional installer you have an obligation to know the product better than the customer. This includes all safety precautions and related items.

Prior to actual installation, thoroughly familiarize yourself with this Instruction Manual. Pay special attention to all safety warnings. Often during installation or repair, it is possible to place yourself in a position which is more hazardous than when the unit is in operation.

Remember, it is your responsibility to install the product safely and to know it well enough to be able to instruct a customer in its safe use.

Safety is a matter of common sense...a matter of thinking before acting. Most dealers have a list of specific good safety practices...follow them.

The precautions listed in this Installation Manual are intended as supplemental to existing practices. However, if there is a direct conflict between existing practices and the content of this manual, the precautions listed here take precedence.

GCTW-01KS-E Thru-the-Wall Sleeve Installation Instructions

1. Assemble the wall sleeve:

PACKING LIST

No.:	Part name	Qty
1	Top cover	1
2	Left cover	1
3	Right cover	1
4	Bottom cover	1
5	Stamped grille	1
6	Attachment bag	1

ATTACHMENT BAG

No.:	Part name	Qty
1	Screw M4*8	8
2	Spring nut	2
3	Flange screw M4*12	2
4	Plastic fix unit	2

A. Insert the spring nuts onto the bottom panel.

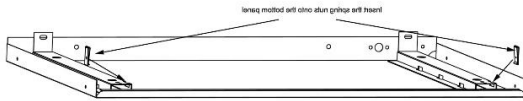

B. Insert the left and right panels onto the bottom panel and secure tightly with screws

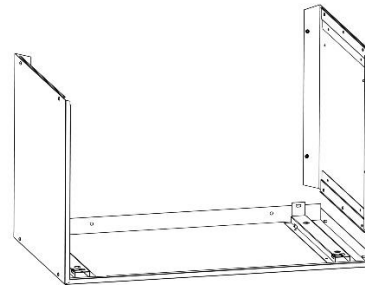

C. Insert the top panel directly onto the assembled left and right panels and secure tightly with screws

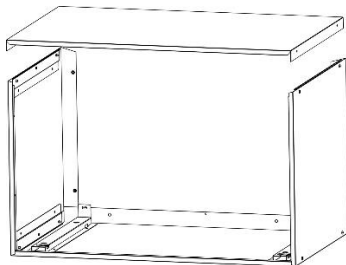

D. Install the stamped grille and fix it from wall sleeve's side with two flange screws.

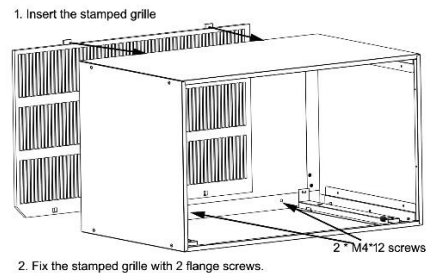

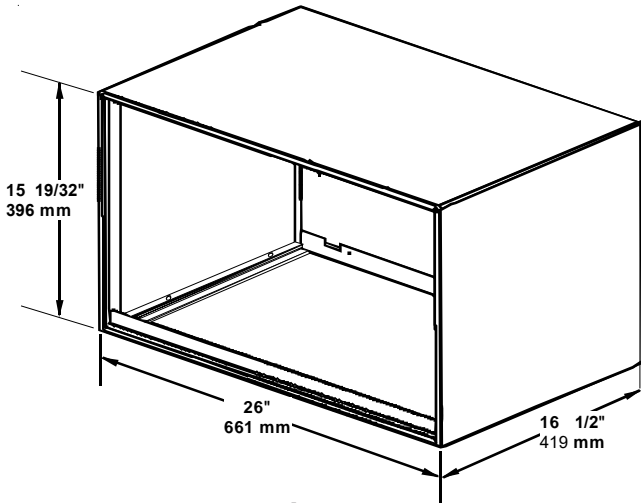

Figure 1
Wall Sleeve Dimensions

Preinstallation Considerations

Before proceeding with the sleeve installation, ensure the following guidelines for locating the wall opening and sleeve are met:

- The wall opening must be the correct size. See Figure 1 for wall sleeve dimensions and Figure 3 for minimum wall opening size.
- The wall sleeve must be installed with a 5" minimum clearance to the floor and 1 1/2" to adjacent walls. See Figure 2 for minimum projections of the sleeve into and out of the room.
- If installed in a concrete or masonry wall, a lintel must be provided in the wall opening for support. **Do not use the wall sleeve as a lintel.** If the wall is less than 8" thick or of hollow construction, an alternate means of support for the sleeve must be provided. See Figure 4 for a typical lintel construction.

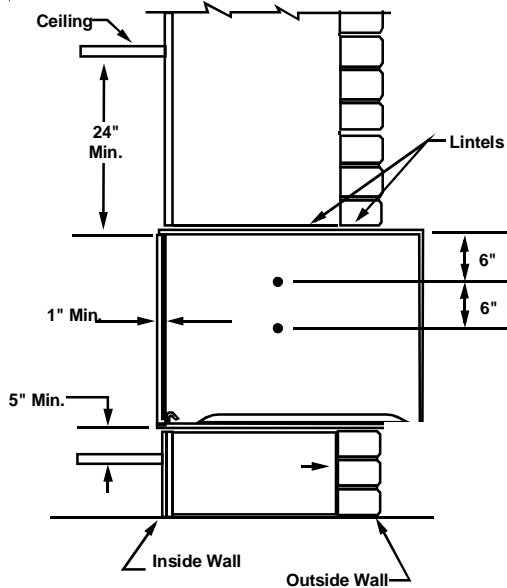

Figure 2
Minimum Unit Clearances

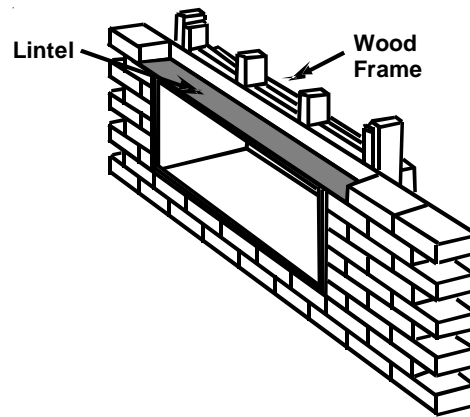

Figure 4
Framing with Lintel

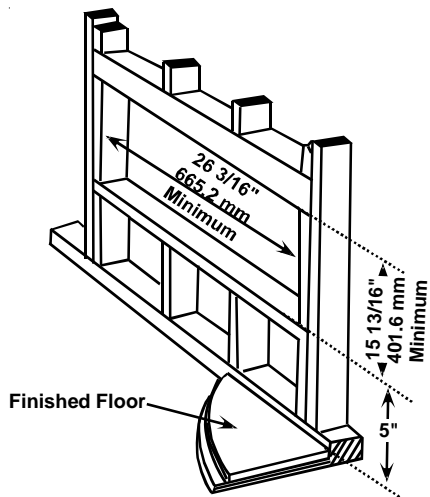

Figure 3
Minimum Wall Opening Dimensions

- When installed in the opening, the wall sleeve must be level from side to side and sloped one quarter bubble front to back. **DO NOT SLOPE THE WALL SLEEVE TOWARD THE ROOM.** See Figure 5.

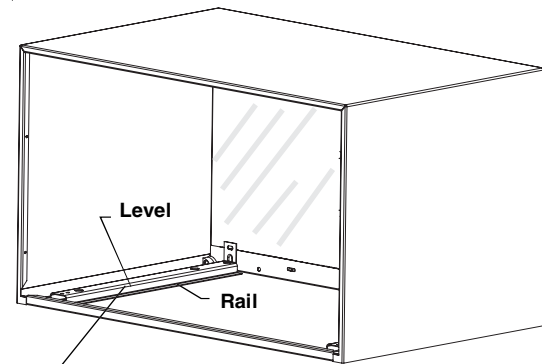

Figure 5
Sleeve Installation

Waterproof barrier should remain in place until the unit is installed. An accessory metal front panel, PBWMFC, is also available, but must be purchased separately.

- Attach the sleeve using four #12x2" wood screws (for wood constructed buildings) or four #12x2" masonry screws (for cement or brick constructed buildings) (Figure 6). Make sure the wall construction is adequate to support the unit.

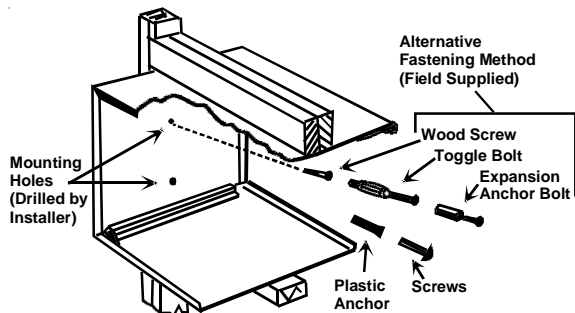

Figure 6
Attaching Wall Sleeve to Opening

- Provide adequate sealing and insulation around the sleeve after it is installed. See Figure 7 for one example of construction.

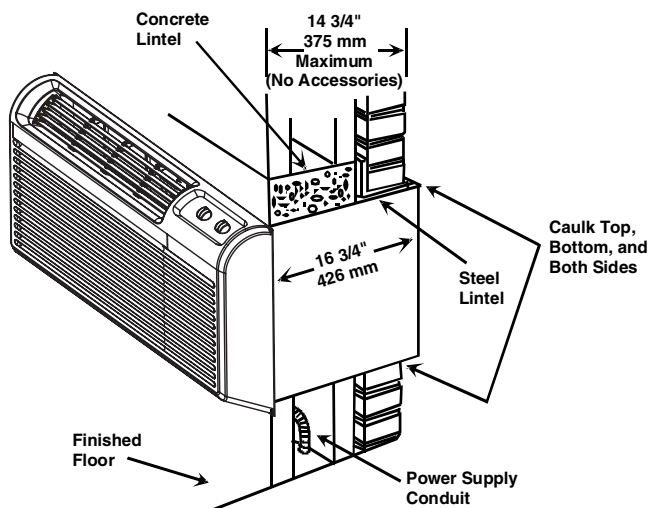

Figure 7
Block and Brick Veneer Installation

- Do not use extension cords with the unit.

Wall Sleeve Installation

After the wall opening is checked and approved for strength, location, size, and clearances, install the wall sleeve as follows:

1. Remove the outside enclosure panel from the wall sleeve.
2. Slide the wall sleeve into the wall opening. Do not distort the cabinet shape to fit the wall opening; the unit chassis must fit snugly and uniformly into the wall sleeve.
3. Locate the sleeve within the range of minimum projections, as shown in Figure 2, so both sides are at least the minimum projection from the wall.
4. Check the level of the wall sleeve. For proper drainage, the sleeve should be level from side to side and one-quarter bubble front to back (outside).
5. Drill two holes in both sides of the wall sleeve so mounting screws can be secured to wall supports. See Figure 6 for location of screw holes. **DO NOT DRILL THROUGH BOTTOM OF SLEEVE.**
6. Check the level of the wall sleeve and adjust if necessary.
7. Caulk or seal around the outside of the entire sleeve.
8. If the unit chassis is not to be installed immediately, replace the enclosure panel on the outside opening of the sleeve to limit weather damage to the building interior.
9. Recycle or dispose of packaging materials according to local codes.

