

GENUINE COMFORT

PACKAGED TERMINAL AIR CONDITIONER/HEAT PUMP

INSTALLATION INSTRUCTIONS & OWNER'S MANUAL

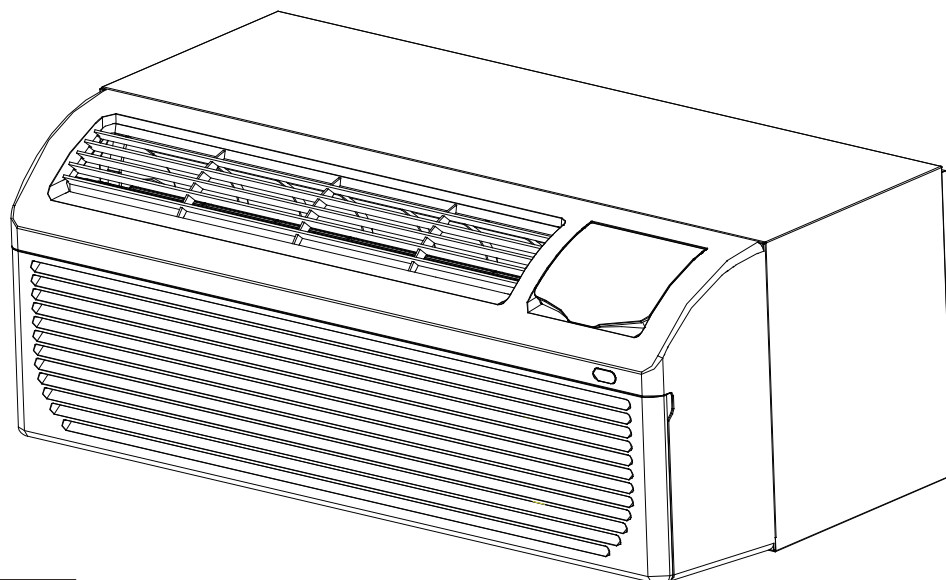

MODELS

GC42P-H07KA2-2	GC42P-H12KD5-2
GC42P-H07KC3-2	GC42P-E12KA2-2
GC42P-E07KA2-2	GC42P-E12KC3-2
GC42P-E07KC3-2	GC42P-E12KD5-2
GC42P-H09KA2-2	GC42P-H15KA2-2
GC42P-H09KC3-2	GC42P-H15KC3-2
GC42P-E09KA2-2	GC42P-H15KD5-2
GC42P-E09KC3-2	GC42P-E15KA2-2
GC42P-H12KA2-2	GC42P-E15KC3-2
GC42P-H12KC3-2	GC42P-E15KD5-2



Genuine Comfort Help Center

ATTENTION INSTALLATION PROFESSIONAL

As a professional installer you have an obligation to know the product better than the customer. This includes all safety precautions and related items.

Prior to actual installation, thoroughly familiarize yourself with this instruction manual. Pay special attention to all safety warnings.

Often during installation or repair it is possible to place yourself in a position which is more hazardous than when the unit is in operation.

Remember it is your responsibility to install the product safely and to know it well enough to be able to instruct a customer in its safe use.

Safety is a matter of common sense, a matter of thinking before acting. Most dealers have a list of specific good safety practices, follow them.

The precautions listed in this Installation Manual are intended as supplemental to existing practices. However, if there a direct conflict between existing practices and the content of this manual, the precautions listed here take precedence.

Model Coding

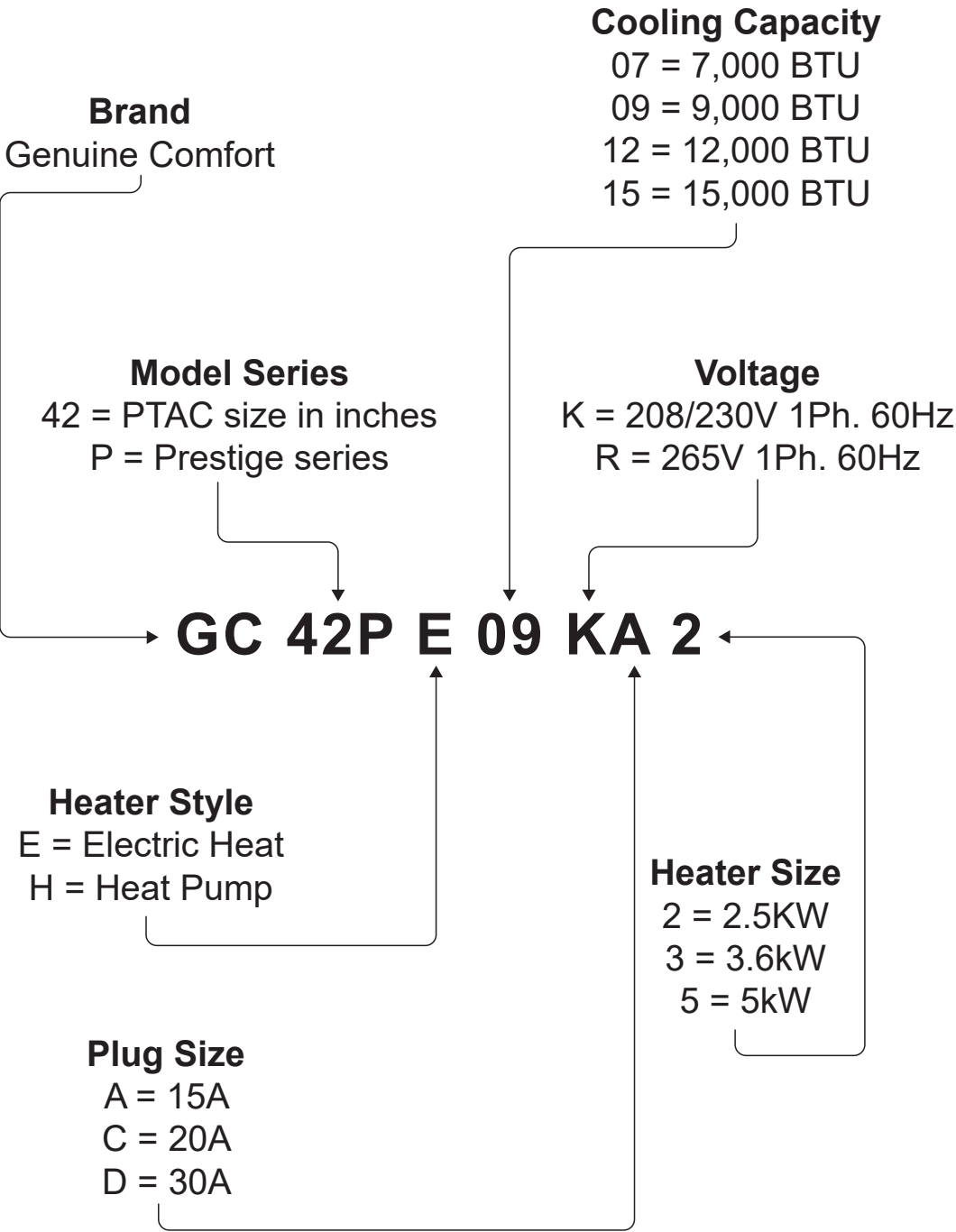

Contents

SAFETY PRECAUTIONS FOR R32 REFRIGERANT.....	7
UNIT FEATURES.....	12
INSTALLATION INSTRUCTION.....	16
WIRING.....	20
OPERATING INSTRUCTIONS (ACCESSORY OPTIONAL).....	22
WALL THERMOSTAT CONTROL.....	26
MAINTENANCE AND CLEANING.....	27
NORMAL OPERATING SOUNDS AND CONDITION.....	29
DIAGNOSTIC CODES.....	29
TROUBLE SHOOTING.....	30

IMPORTANT NOTES:

Before using this manual, check the serial plate for proper model identification.

Due to policy of continual product improvement, the right is reserved to change specifications and design without notice.

QUALIFICATION OF WORKERS

The installation and servicing of this equipment must be performed by qualified, experienced technicians only. Professional installation personnel should have the following experience:

- Installing the electric heater
- Opening of sealed components
- Opening of ventilated enclosures
- Commissioning and troubleshooting
- Checking the electric control part and wiring
- Breaking into the refrigerant circuit and charging

IMPORTANT NOTE TO THE OWNER

This manual is to be used by qualified, professionally trained HVAC technicians only. The manufacturer does not assume any responsibility for property damage or personal injury for improper service procedures or services performed by an unqualified Person.

IMPORTANT NOTE TO THE SERVICER

Read this manual and familiarize yourself with the specific items which must be adhered to before attempting to service this unit. The precautions listed in this Installation Manual are intended as supplemental to existing practices. However, if there is a direct conflict between existing practices and the content of this manual, the precautions listed here take precedence.

WARNING

KEEP ANY REQUIRED VENTILATION OPENINGS CLEAR OF OBSTRUCTION;

NOTICE

SERVICING SHALL BE PERFORMED ONLY AS RECOMMENDED BY THE MANUFACTURER.

WARNING

THE APPLIANCE SHALL BE STORED IN A WELL-VENTILATED AREA WHERE THE ROOM SIZE CORRESPONDS TO THE ROOM AREA AS SPECIFIED FOR OPERATION.

WARNING

THE APPLIANCE SHALL BE STORED IN A ROOM WITHOUT CONTINUOUSLY OPERATING OPEN FLAMES (FOR EXAMPLE AN OPERATING GAS APPLIANCE) AND IGNITION SOURCES (FOR EXAMPLE AN OPERATING ELECTRIC HEATER)

NOTICE

INSTALLATION, SERVICE, MAINTENANCE AND REPAIR OF THIS UNIT MUST BE PERFORMED BY A CERTIFIED TECHNICIAN.

! NOTICE

PRODUCT UNINSTALLATION AND RECYCLING MUST BE PERFORMED BY A CERTIFIED TECHNICIAN.

! NOTICE

THIS APPLIANCE IS NOT INTENDED FOR USE BY PERSONS (INCLUDING CHILDREN) WITH REDUCED PHYSICAL, SENSORY OR MENTAL CAPABILITIES, OR LACK OF EXPERIENCE AND KNOWLEDGE, UNLESS THEY HAVE BEEN GIVEN SUPERVISION OR INSTRUCTION CONCERNING USE OF THE APPLIANCE BY A PERSON RESPONSIBLE FOR THEIR SAFETY.

! NOTICE

CHILDREN SHOULD BE SUPERVISED TO ENSURE THAT THEY DO NOT PLAY WITH THE APPLIANCE.

! NOTICE

IF THE SUPPLY CORD IS DAMAGED, IT MUST BE REPLACED BY THE MANUFACTURER, ITS SERVICE AGENT OR SIMILARLY QUALIFIED PERSONS IN ORDER TO AVOID A HAZARD.

! NOTICE

THE APPLIANCE SHALL BE INSTALLED IN ACCORDANCE WITH NATIONAL WIRING REGULATIONS.

THE FOLLOWING WARNINGS ARE VERY IMPORTANT FOR SAFETY. PLEASE READ THEM CAREFULLY BEFORE INSTALLATION!

1. The air conditioner must be installed by certificated installer. It's forbidden to install by those amateur.
2. Please check whether there is grounding wire in the power supply system before installation. If not, installers should refuse installing and explain the safety principle to users.
3. To avoid electric shock or even death, the socket or terminal blocks for power supply to the air conditioner (include 277V and 115V and 208~230V series and the units that have LCDI power cord) must connect a Ground Fault Circuit Interrupter.
4. During installation, the wire connection must strictly follow the rule which is zero line and fire line of unit should be connected to the zero line and fire line in the power system. The connection in reverse is forbidden. Please be sure the ground wire is firmly connected otherwise it is possible to result in the electrical shock or death.
5. WARNING-Risk of fire. flammable refeigerant used. To be repaired only by trained service personnel. Do not puncture refrigerant tubing. (ATTENTION-Risque d' incendie. Réfrigérant inflammable utilisé. À réparer uniquement par le personnel de service tranined. Ne pas percer les tubes de réfrigérant.)
6. WARNING-Risk of fire. Dispose of properly in accordance with federal or local regulations. Flammable refrigerant used. (AVERTISSEMENT-Risque d' incendie. Éliminez correctement conformément aux réglementations fédérales ou locales. Réfrigérant inflammable utilisé.)
7. WARNING-Risk of fire. Flammable refrigerant used. Consult repair manual/owner' s guide before attempting to service this product. All safety precautions must be followed. (AVERTISSEMENT-Risque d' incendie. Réfrigérant inflammable utilisé. Consultez le manuel de réparation/le guide du propriétaire avant d' essayer d' entretenir ce produit. Toutes les précautions de sécurité doivent être SUIVIES.)
8. WARNING-Risk of fire due to flammable refrigerant used. Follow handling instructions carefully in compliance with national regulations. (ATTENTION-Risque d' incendie dû à l' utilisation d' un fluide frigorigène inflammable. suivre attentivement les instructions de manipulation conformément aux réglementations nationales.)

RECOGNIZE THIS SYMBOL AS A SAFETY PRECAUTION

WARNING

THE MANUFACTURER WILL NOT BE RESPONSIBLE FOR ANY INJURY OR PROPERTY, DAMAGE ARISING FROM IMPROPER SERVICE OR SERVICE PROCEDURES. IF YOU INSTALL OR PERFORM SERVICE ON THIS UNIT, YOU ASSUME RESPONSIBILITY FOR ANY PERSONAL INJURY OR PROPERTY DAMAGE WHICH MAY RESULT, MANY JURISDICTIONS REQUIRE A LICENSE TO INSTALL OR SERVICE HEATING AND AIR CONDITIONING EQUIPMENT.

WARNING





HIGH VOLTAGE
DISCONNECT ALL POWER BEFORE SERVICING OR INSTALLING THIS UNIT. MULTIPLE POWER SOURCES MAY BE PRESENT, FAILURE TO DO SO MAY CAUSE PROPERTY DAMAGE, PERSONAL INJURY OR DEATH.

WARNING

- DO NOT USE MEANS TO ACCELERATE THE DEFROSTING PROCESS OR TO CLEAN, OTHER THAN THOSE RECOMMENDED BY THE MANUFACTURER. (N' UTILISEZ PAS DE MOYENS POUR ACCÉLÉRER LE PROCESSUS DE DÉCONGÉLATION OU POUR NETTOYER, AUTRES QUE CEUX RECOMMANDÉS PAR LE FABRICANT.)
- THE APPLIANCE SHALL BE STORED IN A ROOM WITHOUT CONTINUOUSLY OPERATING IGNITION SOURCES (FOR EXAMPLE: OPEN FLAMES, AN OPERATING GAS APPLIANCE OR AN OPERATING ELECTRIC HEATER.) (L' APPAREIL DOIT ÊTRE ENTREPOSÉ DANS UN LOCAL SANS SOURCES D' INFLAMMATION FONCTIONNANT EN CONTINU (PAR EXEMPLE: FLAMMES NUES, APPAREIL À GAZ EN FONCTIONNEMENT OU CHAUFFAGE ÉLECTRIQUE EN FONCTIONNEMENT).)
- DO NOT PIERCE OR BURN. (NE PERCEZ PAS ET NE BRÛLEZ PAS.)
- BE AWARE THAT REFRIGERANTS MAY NOT CONTAIN AN ODOUR. (SACHEZ QUE LES FRIGORIGÈNES PEUVENT NE PAS CONTENIR D'ODEUR.)

WARNING

RISK OF FIRE, FLAMMABLE REFRIGERANT USED. TO BE REPAIRED ONLY BY TRAINED SERVICE PERSONNEL, DO NOT PUNCTURE REFRIGERANT TUBING, DISPOSE OF PROPERLY IN ACCORDANCE WITH FEDERAL OR LOCAL REGULATIONS.

	WARNING	THIS SYMBOL THAT THIS APPLIANCE USED A FLAMMABLE REFRIGERANT. IF THE REFRIGERANT IS LEAKED AND EXPOSED TO AN EXTERNAL IGNITION SOURCE, THERE IS A RISK OF FIRE.
	CAUTION	THIS SYMBOL THAT THE OPERATION MANUAL SHOULD BE READ CAREFULLY.
	CAUTION	THIS SYMBOL THAT A SERVICE PERSONNEL SHOULD BE HANDLING THIS EQUIPMENT WITH REFERENCE TO THE INSTALLATION MANUAL.
	CAUTION	THIS SYMBOL THAT INFORMATION IS AVAILABLE SUCH AS THE OPERATING MANUAL OR INSTALLATION MANUAL.

SAFETY PRECAUTIONS FOR R32 REFRIGERANT

1. Information on servicing

1.1 Checks to the area

Prior to beginning work on systems containing FLAMMABLE REFRIGERANTS, safety checks are necessary to ensure that the risk of ignition is minimised. For repair to the REFRIGERATING SYSTEM.

1.2 Work procedure

Work shall be undertaken under a controlled procedure so as to minimise the risk of a flammable gas or vapour being present while the work is being performed.

1.3 General work area

All maintenance staff and others working in the local area shall be instructed on the nature of work being carried out. Work in confined spaces shall be avoided.

1.4 Checking for presence of refrigerant

The area shall be checked with an appropriate refrigerant detector prior to and during work, to ensure the technician is aware of potentially toxic or flammable atmospheres. Ensure that the leak detection equipment being used is suitable for use with all applicable refrigerants, i. e. non-sparking, adequately sealed or intrinsically safe.

1.5 Presence of fire extinguisher

If any hot work is to be conducted on the refrigerating equipment or any associated parts, appropriate fire extinguishing equipment shall be available to hand. Have a dry powder or CO₂ fire extinguisher adjacent to the charging area.

1.6 No ignition sources

No person carrying out work in relation to a REFRIGERATING SYSTEM which involves exposing any pipe work shall use any sources of ignition in such a manner that it may lead to the risk of fire or explosion. All possible ignition sources, including cigarette smoking, should be kept sufficiently far away from the site of installation, repairing, removing and disposal, during which refrigerant can possibly be released to the surrounding space. Prior to work taking place, the area around the equipment is to be surveyed to make sure that there are no flammable hazards or ignition risks. "No Smoking" signs shall be displayed.

1.7 Ventilated area

Ensure that the area is in the open or that it is adequately ventilated before breaking into the system or conducting any hot work. A degree of ventilation shall continue during the period that the work is carried out. The ventilation should safely disperse any released refrigerant and preferably expel it externally into the atmosphere.

1.8 Checks to the refrigerating equipment

Where electrical components are being changed, they shall be fit for the purpose and to the correct specification. At all times the manufacturer's maintenance and service guidelines shall be followed. If in doubt, consult the manufacturer's technical department for assistance.

The following checks shall be applied to installations using FLAMMABLE REFRIGERANTS: the actual REFRIGERANT CHARGE is in accordance with the room size within which the refrigerant containing parts are installed;

- the ventilation machinery and outlets are operating adequately and are not obstructed;
- if an indirect refrigerating circuit is being used, the secondary circuit shall be checked for the presence of refrigerant;
- marking to the equipment continues to be visible and legible. Markings and signs that are illegible shall be corrected;
- refrigerating pipe or components are installed in a position where they are unlikely to be exposed to any substance which may corrode refrigerant containing components, unless the components are constructed of materials which are inherently resistant to being corroded or are suitably protected against being so corroded.

1.9 Checks to electrical devices

Repair and maintenance to electrical components shall include initial safety checks and component inspection procedures. If a fault exists that could compromise safety, then no electrical supply shall be connected to the circuit until it is satisfactorily dealt with. If the fault cannot be corrected immediately but it is necessary to continue operation, an adequate temporary solution shall be used. This shall be reported to the owner of the equipment so all parties are advised. Initial safety checks shall include:

- that capacitors are discharged: this shall be done in a safe manner to avoid possibility of sparking;
- that no live electrical components and wiring are exposed while charging, recovering or purging the system;
- that there is continuity of earth bonding.

SAFETY PRECAUTIONS FOR R32 REFRIGERANT

2. Repairs to sealed components

2.1 During repairs to sealed components, all electrical supplies shall be disconnected from the equipment being worked upon prior to any removal of sealed covers, etc. If it is absolutely necessary to have an electrical supply to equipment during servicing, then a permanently operating form of leak detection shall be located at the most critical point to warn of a potentially hazardous situation.

2.2 Particular attention shall be paid to the following to ensure that by working on electrical components, the casing is not altered in such a way that the level of protection is affected. This shall include damage to cables, excessive number of connections, terminals not made to original specification, damage to seals, incorrect fitting of glands, etc.

Ensure that the apparatus is mounted securely.

Ensure that seals or sealing materials have not degraded to the point that they no longer serve the purpose of preventing the ingress of flammable atmospheres. Replacement parts shall be in accordance with the manufacturer's specifications.

3. Repair to intrinsically safe components

Do not apply any permanent inductive or capacitance loads to the circuit without ensuring that this will not exceed the permissible voltage and current permitted for the equipment in use.

Intrinsically safe components are the only types that can be worked on while live in the presence of a flammable atmosphere. The test apparatus shall be at the correct rating.

Replace components only with parts specified by the manufacturer. Other parts may result in the ignition of refrigerant in the atmosphere from a leak.

NOTE: The use of silicon sealant can inhibit the effectiveness of some types of leak detection equipment. Intrinsically safe components do not have to be isolated prior to working on them.

4. Cabling

Check that cabling will not be subject to wear, corrosion, excessive pressure, vibration, sharp edges or any other adverse environmental effects. The check shall also take into account the effects of aging or continual vibration from sources such as compressors or fans.

5. Detection of flammable refrigerants

Under no circumstances shall potential sources of ignition be used in the searching for or detection of refrigerant leaks. A halide torch (or any other detector using a naked flame) shall not be used.

The following leak detection methods are deemed acceptable for all refrigerant systems. Electronic leak detectors may be used to detect refrigerant leaks but, in the case of FLAMMABLE REFRIGERANTS, the sensitivity may not be adequate, or may need re-calibration. (Detection equipment shall be calibrated in a refrigerant-free area.) Ensure that the detector is not a potential source of ignition and is suitable for the refrigerant used. Leak detection equipment shall be set at a percentage of the LFL of the refrigerant and shall be calibrated to the refrigerant employed, and the appropriate percentage of gas (25 % maximum) is confirmed.

Leak detection fluids are also suitable for use with most refrigerants but the use of detergents containing chlorine shall be avoided as the chlorine may react with the refrigerant and corrode the copper pipe-work NOTE Examples of leak detection fluids are

- bubble method,
- fluorescent method agents.

If a leak is suspected, all naked flames shall be removed/extinguished.

If a leakage of refrigerant is found which requires brazing, all of the refrigerant shall be recovered from the system, or isolated (by means of shut off valves) in a part of the system remote from the leak.

6. Removal and evacuation

When breaking into the refrigerant circuit to make repairs – or for any other purpose – conventional procedures shall be used. However, for flammable refrigerants it is important that best practice be followed, since flammability is a consideration. The following procedure shall be adhered to:

SAFETY PRECAUTIONS FOR R32 REFRIGERANT

- a) safely remove refrigerant following local and national regulations;
- b) purge the circuit with inert gas;
- c) evacuate (optional for A2L);
- d) purge with inert gas (optional for A2L);
- e) open the circuit by cutting or brazing.

The refrigerant charge shall be recovered into the correct recovery cylinders if venting is not allowed by local and national codes. For appliances containing flammable refrigerants, the system shall be purged with oxygen-free nitrogen to render the appliance safe for flammable refrigerants. This process might need to be repeated several times.

Compressed air or oxygen shall not be used for purging refrigerant systems. For appliances containing flammable refrigerants, refrigerants purging shall be achieved by breaking the vacuum in the system with oxygen-free nitrogen and continuing to fill until the working pressure is achieved, then venting to atmosphere, and finally pulling down to a vacuum (optional for A2L). This process shall be repeated until no refrigerant is within the system (optional for A2L). When the final oxygen-free nitrogen charge is used, the system shall be vented down to atmospheric pressure to enable work to take place. Ensure that the outlet for the vacuum pump is not close to any potential ignition sources and that ventilation is available.

7. Charging procedures

In addition to conventional charging procedures, the following requirements shall be followed.

- Ensure that contamination of different refrigerants does not occur when using charging equipment. Hoses or lines shall be as short as possible to minimise the amount of refrigerant contained in them.
- Cylinders shall be kept in an appropriate position according to the instructions.
- Ensure that the REFRIGERATING SYSTEM is earthed prior to charging the system with refrigerant.
- Label the system when charging is complete (if not already).
- Extreme care shall be taken not to overfill the REFRIGERATING SYSTEM.

Prior to recharging the system, it shall be pressure-tested with the appropriate purging gas. The system shall be leak-tested on completion of charging but prior to commissioning. A follow up leak test shall be carried out prior to leaving the site.

8. Decommissioning

Before carrying out this procedure, it is essential that the technician is completely familiar with the equipment and all its detail. It is recommended good practice that all refrigerants are recovered safely. Prior to the task being carried out, an oil and refrigerant sample shall be taken in case analysis is required prior to re-use of recovered refrigerant. It is essential that electrical power is available before the task is commenced.

- a) Become familiar with the equipment and its operation.
- b) Isolate system electrically.
- c) Before attempting the procedure, ensure that:
 - mechanical handling equipment is available, if required, for handling refrigerant cylinders;
 - all personal protective equipment is available and being used correctly;
 - the recovery process is supervised at all times by a competent person;
 - recovery equipment and cylinders conform to the appropriate standards.
- d) Pump down refrigerant system, if possible.
- e) If a vacuum is not possible, make a manifold so that refrigerant can be removed from various parts of the system.
- f) Make sure that cylinder is situated on the scales before recovery takes place.
- g) Start the recovery machine and operate in accordance with instructions.
- h) Do not overfill cylinders (no more than 80% volume liquid charge).
- i) Do not exceed the maximum working pressure of the cylinder, even temporarily.
- j) When the cylinders have been filled correctly and the process completed, make sure that the cylinders and the equipment are removed from site promptly and all isolation valves on the equipment are closed off.
- k) Recovered refrigerant shall not be charged into another REFRIGERATING SYSTEM unless it has been cleaned and checked.

SAFETY PRECAUTIONS FOR R32 REFRIGERANT

9. Labelling

Equipment shall be labelled stating that it has been de-commissioned and emptied of refrigerant. The label shall be dated and signed. For appliances containing FLAMMABLE REFRIGERANTS, ensure that there are labels on the equipment stating the equipment contains FLAMMABLE REFRIGERANT.

10. Recovery

When removing refrigerant from a system, either for servicing or decommissioning, it is recommended good practice that all refrigerants are removed safely.

When transferring refrigerant into cylinders, ensure that only appropriate refrigerant recovery cylinders are employed. Ensure that the correct number of cylinders for holding the total system charge is available. All cylinders to be used are designated for the recovered refrigerant and labelled for that refrigerant (i. e. special cylinders for the recovery of refrigerant). Cylinders shall be complete with pressure-relief valve and associated shut-off valves in good working order. Empty recovery cylinders are evacuated and, if possible, cooled before recovery occurs. The recovery equipment shall be in good working order with a set of instructions concerning the equipment that is at hand and shall be suitable for the recovery of all appropriate refrigerants including, when applicable, FLAMMABLE REFRIGERANTS. In addition, a set of calibrated weighing scales shall be available and in good working order. Hoses shall be complete with leak-free disconnect couplings and in good condition. Before using the recovery machine, check that it is in satisfactory working order, has been properly maintained and that any associated electrical components are sealed to prevent ignition in the event of a refrigerant release. Consult manufacturer if in doubt.

The recovered refrigerant shall be returned to the refrigerant supplier in the correct recovery cylinder, and the relevant waste transfer note arranged. Do not mix refrigerants in recovery units and especially not in cylinders.

If compressors or compressor oils are to be removed, ensure that they have been evacuated to an acceptable level to make certain that FLAMMABLE REFRIGERANT does not remain within the lubricant. The evacuation process shall be carried out prior to returning the compressor to the suppliers. Only electric heating to the compressor body shall be employed to accelerate this process. When oil is drained from a system, it shall be carried out safely.

11. WARNING FOR USING R32 REFRIGERANT

- Appliance shall be installed, operated and stored in a room with a floor area larger than 4 m².
- Appliance shall not be installed in an unventilated space, if that space is smaller than 4 m².
- Compliance with national gas regulations shall be observed.
- The appliance shall be stored so as to prevent mechanical damage from occurring.
- Any person who is involved with working on or breaking into a refrigerant circuit should hold a current valid certificate from an industry-accredited assessment authority, which authorises their competence to handle refrigerants safely in accordance with an industry recognised assessment specification.
- Servicing shall only be performed as recommended by the equipment manufacturer. Maintenance and repair requiring the assistance of other skilled personnel shall be carried out under the supervision of the person competent in the use of flammable refrigerants.
- Please follow the instruction carefully to handle, install, clear, service the air conditioner to avoid any damage or hazard. Flammable Refrigerant R32 is used within air conditioner. When maintaining or disposing the air conditioner, the refrigerant (R32) shall be recovered properly, shall not discharge to air directly.
- No any open fire or device like switch which may generate spark/arcing shall be around air conditioner to avoid causing ignition of the flammable refrigerant used.
- Please follow the instruction carefully to store or maintain the air conditioner to prevent mechanical damage from occurring.
- Flammable refrigerant -R32 is used in air conditioner. Please follow the instruction carefully to avoid any hazard.

12. Installation & Assembly Instructions

- Before installing the appliance, you must read the manual carefully to get the safety information and notes.
- Unit refrigerant charge amount: refer to unit name plate marking.
- A leak test must be done after the installation is completed.
- It is a must to do the safety inspection before maintaining or repairing an air conditioner using combustible refrigerant in order to ensure that the fire risk is reduced to minimum.

SAFETY PRECAUTIONS FOR R32 REFRIGERANT

- It is necessary to operate the machine under a controlled procedure in order to ensure that any risk arising from the combustible gas or vapor during the operation is reduced to minimum.

13. Please note that:

1. Handle gently.
2. At least two people needed to lift the chassis and prohibit lift the copper pipes.
3. Only trained or qualified people for installation.
4. The installation site should be in a well-ventilated condition.
5. The sites for installing and maintaining an air conditioner using Refrigerant R32 should be free from open fire or welding, smoking, drying oven or any other heat source higher than 548°C which easily produces open fire.
6. When installing an air conditioner, it is necessary to take appropriate anti-static measures such as wear anti-static clothing and/or gloves.
7. It is necessary to choose the site convenient for installation or maintenance wherein the air inlets and outlets of the indoor and outdoor units should be not surrounded by obstacles or close to any heat source or combustible and/or explosive environment.
8. If the indoor unit suffers refrigerant leak during the installation, all the personnel should go out till the refrigerant leaks completely for 15 minutes. If the product is damaged, it is a must to carry such damaged product back to the maintenance station and it is prohibited to weld the refrigerant pipe or conduct other operations on the user's site.
9. It is necessary to choose the place where the inlet and outlet air of the indoor unit is even.
10. It is necessary to avoid the places where there are other electrical products, power switch plugs and sockets, kitchen cabinet, bed, sofa and other valuables right under the lines on two sides of the indoor unit, and also prevent mechanical damage from occurring.

UNIT FEATURES

This unit has many features which are different than those found on conventional PTAC units. The servicer must be familiar with these features in order to properly handle the unit .

- **LCDI Cords** - Underwriters Laboratories and the National Electric Code (NEC) now require power cords that sense current leakage and can open the electrical circuit to the unit on units rated at 250 volts or less. In the event that unit does not operate, check the reset button located on or near the head of the power cord as part of the normal troubleshooting procedure.

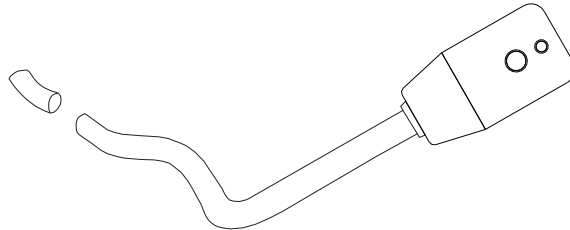

LCDI power Cord

- **Automatic 3-minute compressor lockout** - After the compressor cycles off, it will not restart for three minutes.
- **Random restart delay** - To help eliminate power surges after a power outage, the unit is equipped with a two to four minute random restart delay feature. Whenever the unit is plugged in with the master switch turned on and the mode switch set in the cool or heat mode, a random restart will occur. A random restart condition can be avoided by setting the mode switch in the fan only or off position before applying power to the unit.
- **Indication LEDs** - The control panel has LEDs that correspond to fan operation and to indicate unit status. The LEDs next to the selections ON/OFF, FAN, COOL, and HEAT indicate which operational mode is active.

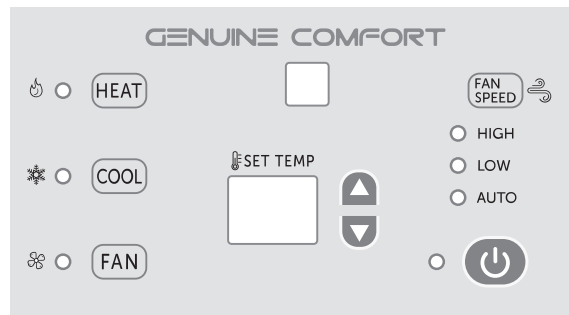

- **High Pressure Protection** - The unit will shut off automatically when the pressure in the system is over 638 psi and within 10 minutes, after the compressor turns off, the unit will restart when the pressure turns back below 551 psi. This protection can effectively avoid the burst and leakage of pipes, lessen the system failures and prolong the service life.
- **Failure Tolerance** - If the unit is in protection mode less than 4 times in one hour, the accumulation times will reset to avoid system failure. Only when the unit enters protection mode more than 4 times in one hour, the system will fail to restart automatically and need manual restart.
- **Standard Physical Dimensions** - The series PTAC is with the same dimensions 42" wide x 16" high x 13-3/4" deep Replacement of older units is made easy. Weather-Protected Electrical Components-Vital electrical components are protected from the weather by locating them on the indoor side of the weather barrier.
- **Highly Featured Microprocessor Controls** - Microprocessor controls are programmed to interface with the temperature sensors to maximize comfort conditions for the room occupant and provide outstanding features. Thermistors are used to sense small changes in temperature to give excellent room control and allow the microprocessor to monitor and react to changing conditions.
- **Automatic Emergency Heat on Heat Pump Units** - Automatically uses electric resistance heat if the heat pump fails.
- **High-Temperature Heat Pump Operation Protection** - Automatically protects the compressor if heat pump is operated with high indoor coil temperatures. Power to the outdoor fan and the compressor are turned off if the indoor coil gets too hot during heat pump operation to prevent damage to the compressor.

UNIT FEATURES

- **Fan Motors Permanently Lubricated** - All units have two fan motors for quiet operation and maximum operating efficiency.
Motors are permanently lubricated to reduce maintenance and totally enclosed to keep dirt and water out of the motor windings.
- **Indoor Fan Speed Selections LOW /HIGH** - Unit may be operated in low fan speed or high fan speed. Some speed may not be present based on unit capacities.
- **Rotary Compressor** - Smoother operation for quiet, dependable service and high efficiency.
- **Indoor Coil Frost Control** - Prevents indoor coil from freezing. Frost can form on the indoor coil when the unit is operated in cooling when the outdoor temperature is low. The unit automatically shuts the compressor off until the indoor coil temperature warms to the point where frosting will no longer occur. Then restart the compressor.
- **FD Control (front-desk control)** - The unit can be turned ON/OFF by front desk control switch. The control wire, colored purple, locates in the wall mounted thermostat interface (refer to Fig. 9 on page 14).
- **Self-evaporating system** for condensate management. This feature negates the necessity for an external drain line by utilizing a slinger fan (outdoor fan), which effectively disperses the condensate over the condenser coil. As the unit operates, the heat from the condenser evaporates the water, ensuring that the system remains efficient and eliminates the potential for water accumulation.
- **Room Freeze Protection**
- **Outside Fresh Air ventilation manual control** - 45/50 CFM.

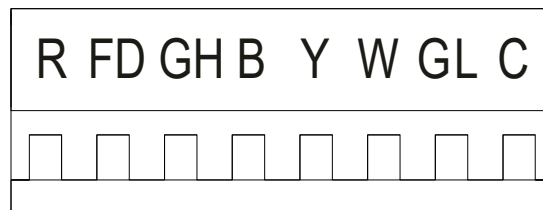

The control logic as below:

1. Turn ON unit: connect R to FD.
2. Turn OFF unit: disconnect R to FD.

! WARNING

HIGH VOLTAGE
DISCONNECT ALL POWER BEFORE SERVICING OR INSTALLING THIS UNIT. MULTIPLE POWER SOURCES MAY BE PRESENT, FAILURE TO DO SO MAY CAUSE PROPERTY DAMAGE, PERSONAL INJURY OR DEATH.

UNIT ACCESSORIES

This unit is designed for through-the-wall installation in new or existing buildings. To complete the installation of this PTAC, an insulated wall sleeve and an outdoor grille (either the stamped aluminum grille, or the architectural grille) are required.

The chassis and the cabinet front are shipped in one carton. Optional accessories to complete a particular installation are the following:

OPTIONAL ACCESSORIES

Power switch Kit

Key Lock Kit

Filter Kit

Wire Harness Kit

Stamped Louver Kit

Wireless IR Antenna

IR REMOTE CONTROLLER

Wall Sleeve Kit

Drain Kit

Hard Wire Kit

Architectural Grille Kit

LCDI Power Cord

Wireless IR Thermostat

NOTE: Consult sales literature for the appropriate voltage and amperage selections, if applicable.

UNIT FEATURES

• Special Control Functions for DIP Switches

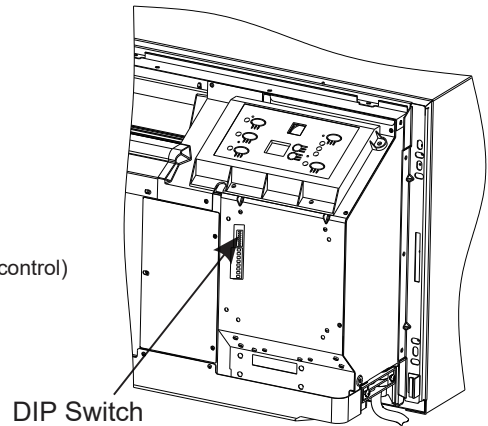
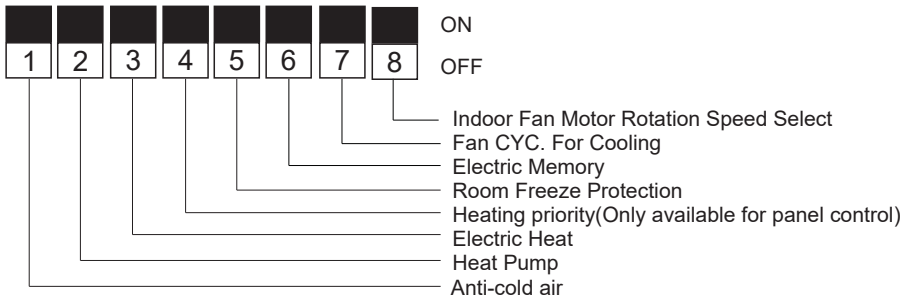

Switch	Description	Function	Factory Setting
#1	Anti-cold air	ON-Enable; OFF-Disable;	OFF
#2	Heat Pump	ON-Enable; OFF-Disable;	HP : ON AC : OFF
#3	Electric Heat	ON-Enable; OFF-Disable;	With E-HEAT : ON Without E-HEAT : OFF
#4	Heating priority	ON-Heat Pump Prior; OFF-Electric Heat Prior; (Only available for panel control)	HP : ON AC : OFF
#5	Room Freeze Protection	ON-Allows the unit to ensure the indoor room temperature does not fall below 40°F even when turned off; OFF-disable freeze protection.	HP : ON AC with electric heat : ON AC without electric heat : OFF
#6	Electric Memory	ON-Enable; OFF-Disable;	ON
#7	Fan CYC. For Cooling	ON-Enable; OFF-Disable;	OFF
#8	Indoor Fan Motor Rotation Speed Select	ON-7K/9K fan motor rotation speed; OFF-12K/15K fan motor rotation speed	7K/9K : ON 12K/15K : OFF

UNIT FEATURES

#1 Anti-cold air Enabled (left) or Disabled (right)

When this switch is Enabled (left), When the temperature of the indoor coil is low, the internal fan automatically switches to low fan to ensure the unit air outlet at a high temperature. When the temperature of the indoor coil increases, the internal fan automatically switches to high fan. This function is designed for human comfort.

When switch #2 is Disabled (right), #1 functional failure. For switch #1, the factory default for 15K heat pump model is On, while other models are Off.

#2 Heat Pump Enabled (left) or Disabled (right)

When this switch is disabled (right), heat pump will never operate.

#3 Electric Heat Enable (left) or Disabled (right)

When this switch is disabled (right), electric heater will never operate.

#4 Heating Priority Enable (left) or Disabled (right)

This function is only for heat pump with electric heater model. When this switch is right, electric heat takes priority. When this switch is left, heat pump takes priority.

#5 Auto Heating (Freeze Protect)

The unit must have heating function (cooling only mode does not share this function). When the unit is connected to the power supply, and room temperature is lower than 10°C/50°F for 3 minutes, unit will start heating automatically no matter what the setting mode is. Only when room temperature reaches 13°C/55°F will heating stop.

#6 Electric Power-Off Memory. Enable(left) or Disabled(right)

After power on, the unit will operate the same settings as before power off. The default setting is enabled(left).

#7 Fan CYC. For cooling

The owner may choose either fan cycling or fan continuous mode (cooling mode) based on their preference.

The cycle fan only operates when cooling or heating is required, thus conserving energy. When this switch is Enabled (left), in cooling mode, when the indoor ambient temperature reaches the set temperature, and the internal fan stops running. When this switch is Disabled (right), in the cooling mode, when the indoor ambient temperature reaches the set temperature, and the internal fan runs continuously.

#8 Indoor Fan Motor Rotation Speed Select

Enabled (left), ON-7K/9K fan motor rotation speed; Disabled (right), OFF-12K/15K fan motor rotation speed.

INSTALLATION INSTRUCTIONS

To ensure that the unit operates safely and efficiently, it must be installed, operated and maintained according to these installation and operating instructions and all local codes and ordinances or, in their absence, with the latest edition of the National Electric Code. The proper installation of this unit is described in the following sections. Following the steps in the order presented should ensure proper installation.

! WARNING

HIGH VOLTAGE
DISCONNECT ALL POWER BEFORE SERVICING OR INSTALLING THIS UNIT. MULTIPLE POWER SOURCES MAY BE PRESENT, FAILURE TO DO SO MAY CAUSE PROPERTY DAMAGE, PERSONAL INJURY OR DEATH.

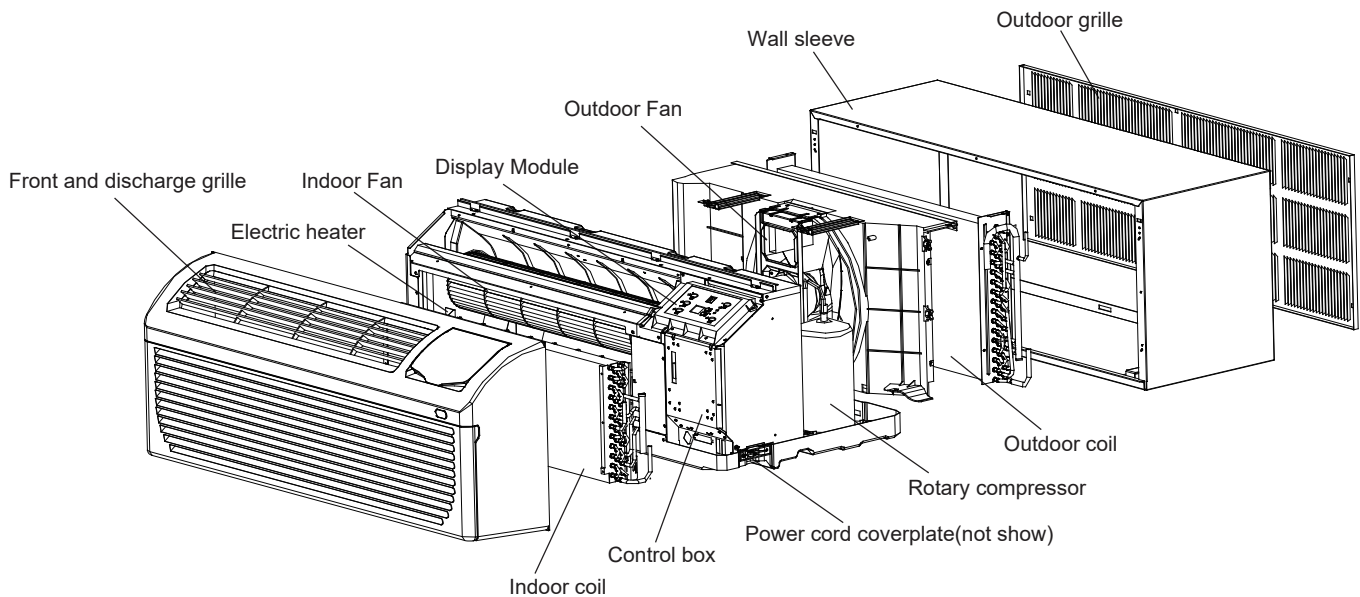

WALL SLEEVE ASSEMBLY (OPTIONAL ACCESSORY)

Two kinds of wall sleeve are optional for customers, one is reassemble wall sleeve and the other one is welding integrated wall sleeve.

Removable Wall Sleeve

The removable wall sleeve can be removed and occupies less space and is convenient to transport. Follow the below steps to install:

- Unpack all parts and accessories, referring to Fig 1.
- Assemble the wall sleeve by first "clip locking" the side pieces to the bottom piece.
- Assemble the top piece to the assembled side and top piece.

Welded integrated wall sleeve

Welded integrated wall sleeve is featured by artistic appearance and stable structure referring to Fig 2.

Customers can purchase together with unit. If the wall covers are not purchased together, the user must purchase a wall cover that meets the G90 standard or salt spray test.

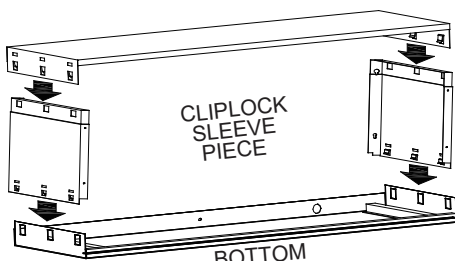

Fig 1

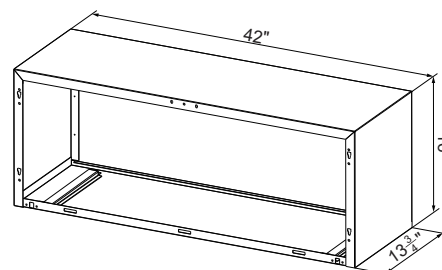

Fig 2

INSTALLATION INSTRUCTIONS

SLEEVE INSTALLATION

Wall sleeve location

When making the wall opening, please observe the following requirement:

- A) The air inlet and outlet should be unblocked and the air can be delivered to every corner of the room
- B) Install the unit in places that are away from heat source or sources of flammable gases.
- C) Do not install the unit in places that are subject to strong dust
- D) Do not install the unit in places where the operational noise and exhausted air might trouble your neighbour.
- E) There should be sufficient space margins around the unit to facilitate maintenance and repairs(refer to Figs 3 and 4)

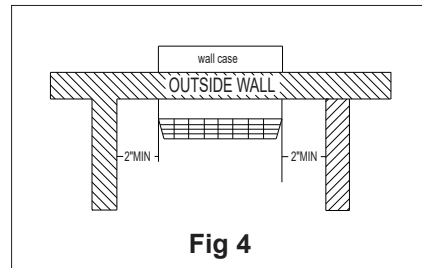
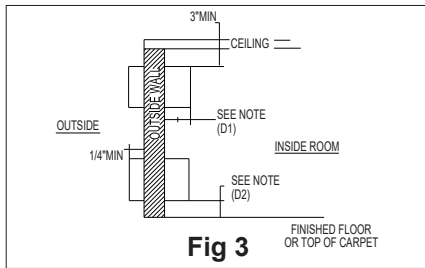

Chart 1

Dimensions	Recommended installation clearance
D1	Projection of case into room-1/2" minimum up to 1-3/4" maximum without use of electrical sub-base. Note: 2-3/8" minimum when sub-base is used.
D2	Height above finished floor or top of carpet-1/2" minimum, 2" recommended without sub-base-3" minimum with sub-base.

Preparation of the wall

The sleeve should be installed during construction and lintels should be used to support the block above the wall sleeve. The sleeve can not support the load of bricks/ blocks.

For existing construction, wall opening must be created, the proper dimensions are necessary to avoid use of fillers or additional framing. The sleeve is modular in height and width(refer to Fig 5 & Chart 2).

Height:

Fits 2 courses concrete block

Fits 6 courses standard brick

Fits 5 courses jumbo brick

Width:

Fit approximately 3 stud spaces.

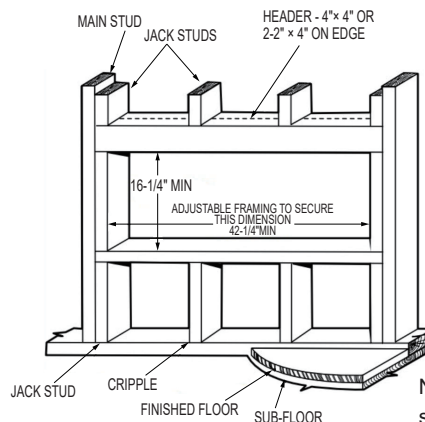

Fig 5

Note: Do not remove the stiffener support from inside the wall case until the chassis is to be installed.

INSTALLATION INSTRUCTIONS

Chart 2

	minium finished opening dimensions		sleeve dimensions		
	Height	width	height	width	depth
NO.1	16-1/4"	42-1/2"	16"	42"	13-3/4" (16"/18"/24")
NO.2	16-1/4"	42-1/4"			

NOTE: NO.1 means using field supplied sleeve angles
 NO.2 means not using field supplied sleeve angles

In order for condensate water to drain properly inside the unit, the sleeve must be installed properly:

- Level from right to left.
- A slight downward pitch from the indoor side to the out-door side as shown below(Fig 6).
- Fasten the wall sleeve(Fig 7).

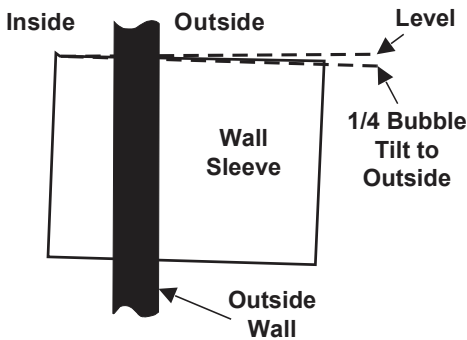

Fig 6 Proper Sleeve Tilt

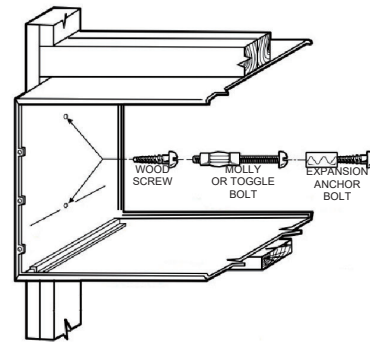

Fig 7

OUTDOOR GRILLE (OPTIONAL ACCESSORY)

An outside grille must be installed to direct air flow for proper unit operation and also protect the outdoor coil. The grille must be installed before installing the chassis.

When replacing an old chassis with an existing grille or using a specialized grille in a new installation, please check with after-sales engineer of supplier to determine if the new chassis should be used with the nonstandard specialized grille. An improper outdoor grille can decrease cooling or heating capacity, increase energy usage and shorten compressor life and possibly void the warranty.

Flush Stamped Louver

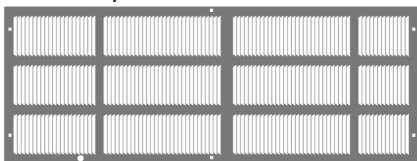

Architectural Louver



CHASSIS INSTALLATION

1. Remove the cabinet front from the chassis as described in Front Removal.
2. Insert the chassis into the wall sleeve.

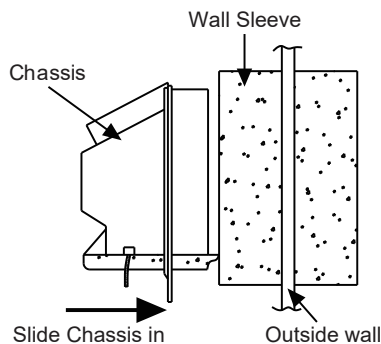

Chassis Installation View 1

INSTALLATION INSTRUCTIONS

3. Slide the chassis into the wall sleeve until the chassis flanges contact the front edge of the wall sleeve.

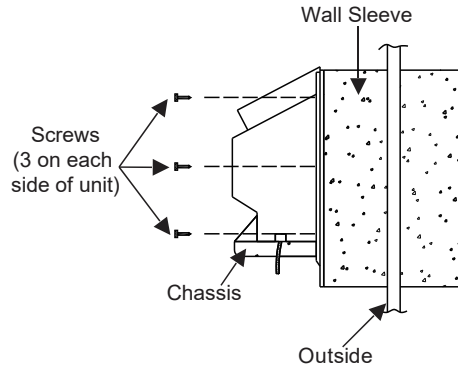

Chassis Installation View 2

4. Secure the chassis to the wall sleeve using three screws on each side of the chassis to ensure a proper seal between the chassis and the wall sleeve. The screws are supplied in a plastic bag.

IMPORTANT NOTES:

1. The unit is equipped with a rubber grommet mounted compressor. These grommets are factory set and require no adjustment.
2. Check the indoor and outdoor grilles for obstructions to air flow. The unit must be located where curtains, furniture, trees, or other objects do not block the air flow to and from the unit. If air is obstructed and/or deflected back into the unit, the air conditioner compressor may cycle on and off rapidly. This could damage the compressor or possibly void the warranty.

FRONT REMOVAL

1. Grasp the cabinet front.

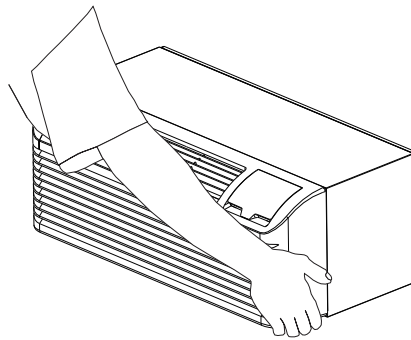

Cabinet Front Removal View 1

2. Pull the bottom of the cabinet front away from the chassis until the retaining clips disengage.

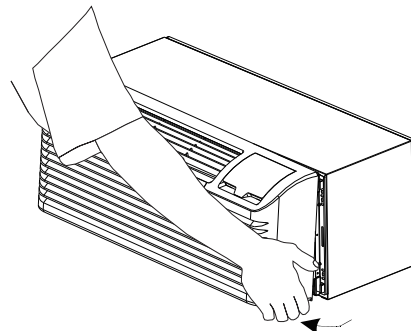

Cabinet Front Removal View 2

3. Lift the cabinet front off the chassis. Reverse this procedure to reinstall the cabinet front.

WIRING

Cord connection to a wall socket is not permitted for 265V units. All 265V units must be hard wired using the hard wire kit or make use of the plug in receptacle in the standard subbase.

230~208V units are equipped with LCDI power cords and can open the electrical circuit to the unit. In the event the unit does not operate, check the reset button located on or near the head of the power cord as part of the normal trouble shooting procedure.

WARNING

HIGH VOLTAGE

DISCONNECT ALL POWER BEFORE SERVICING OR INSTALLING THIS UNIT. MULTIPLE POWER SOURCES BE PRESENT, FAILURE TO DO SO MAY CAUSE PROPERTY DAMAGE, PERSONAL INJURY OR DEATH.

DO NOT SERVICE THIS UNIT WITHOUT FIRST SHUTTING OFF THE POWER TO THE UNIT FROM THE CIRCUIT BREAKER AND/OR REMOVING THE UNIT CORD SET PLUG FROM THE WALL OUTLET.

WARNING

TO AVOID THE RISK OF PROPERTY DAMAGE, PERSONAL INJURY OR FIRE, USE ONLY COPPER CONDUCTORS.

WARNING

TO AVOID PROPERTY DAMAGE, PERSONAL INJURY OR DEATH DUE TO ELECTRICAL SHOCK, DO NOT USE AN EXTENSION CORD WITH THIS UNIT.

WARNING

TO AVOID THE RISK OF PROPERTY DAMAGE, PERSONAL INJURY OR FIRE DO NOT INSTALL WITH POWER CORD STRETCHED OR UNDER A STRAIN AS THIS MAY CREATE LOOSE PLUG/RECEPTACLE CONNECTION.

WARNING

TO AVOID THE RISK OF PERSONAL INJURY, WIRING TO THE UNIT MUST BE PROPERLY POLARIZED AND GROUNDED.

WARNING

THIS AIR CONDITIONER IS NOT MEANT TO PROVIDE UNATTENDED COOLING OR LIFE SUPPORT FOR PERSONS OR ANIMALS WHO ARE UNABLE REACT TO THE FAILURE OF THIS PRODUCT. THE FAILURE OF AN UNATTENDED AIR CONDITIONER MAY RESULT IN EXTREME HEAT IN THE CONDITIONED SPACE CAUSING OVERHEATING OR DEATH OF PERSONS OR ANIMALS.

VOLTAGE MEASUREMENTS

Once the unit is properly wired, measure the unit supply voltage. Voltage must fall within the voltage utilization range given in Chart 3.

WIRING

Operating Voltage		
Unit Voltage	Voltage Utilization Range	
Rating	Minimum	Maximum
230/208	187	253
265	238	292

Chart 3 - Operating Voltage

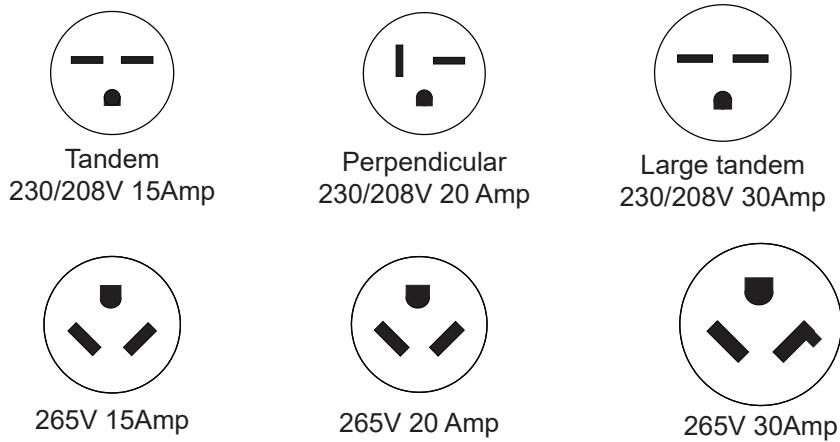

Fig 8 Receptacles/Sub-bases

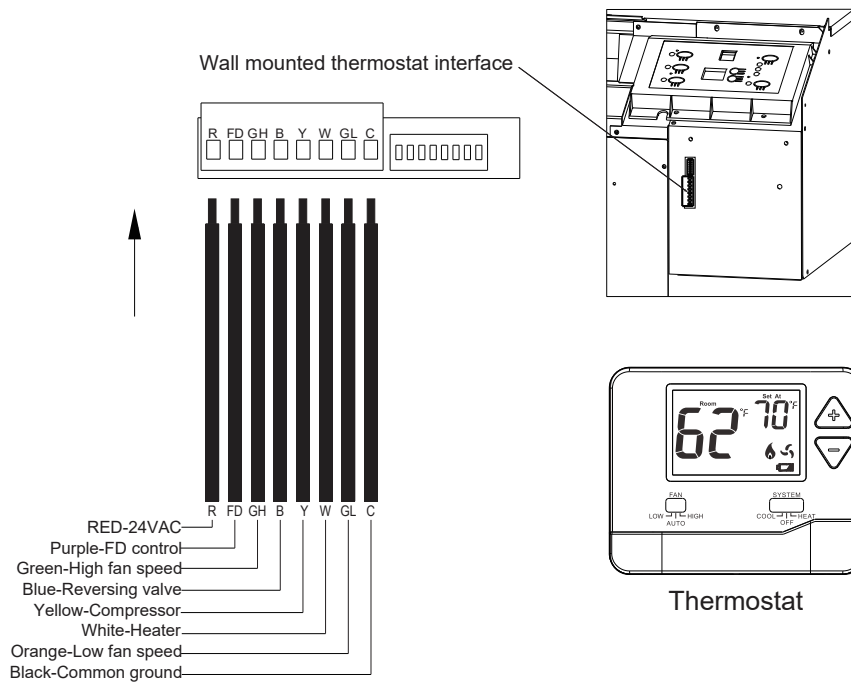

Fig 9 Wall mounted thermostat wiring

NOTE: You should use the Green Connector in the unit for wiring the wall mounted thermostat. The Green Connector definition refers to the above figure. For details of operation, see the “Remote Thermostat Change” instructions chapter on page 11.

OPERATING INSTRUCTIONS (ACCESSORY OPTIONAL)

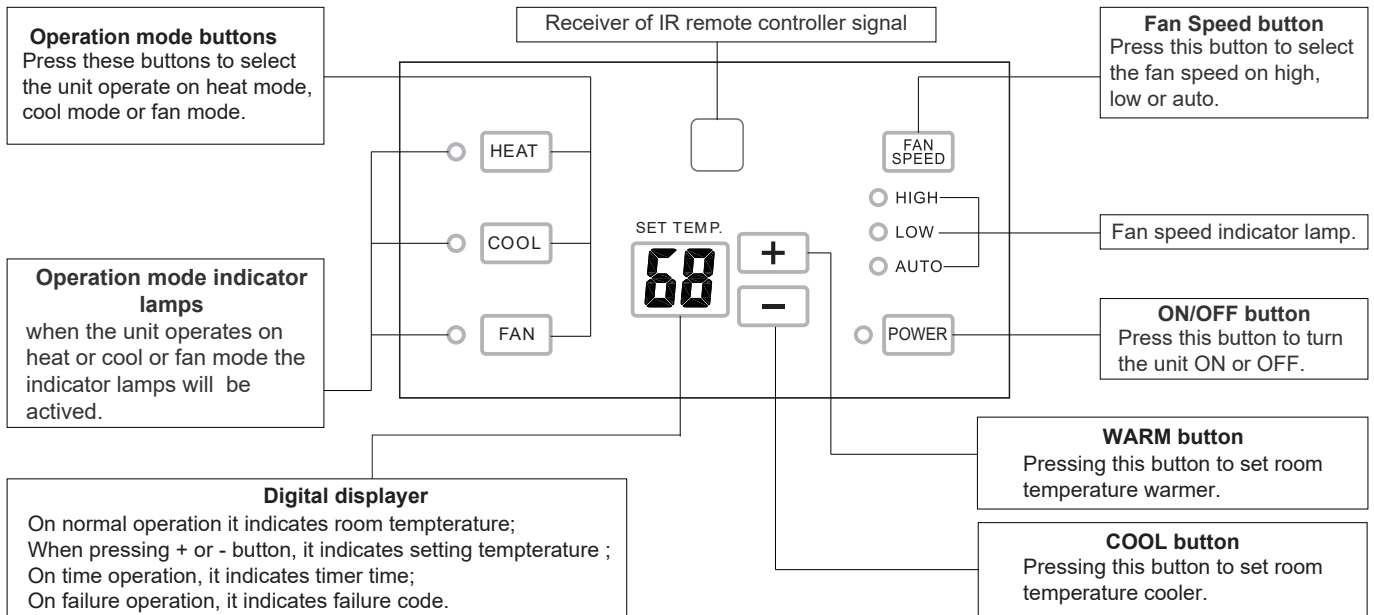

Fig 10 Use of unit mounted control panel

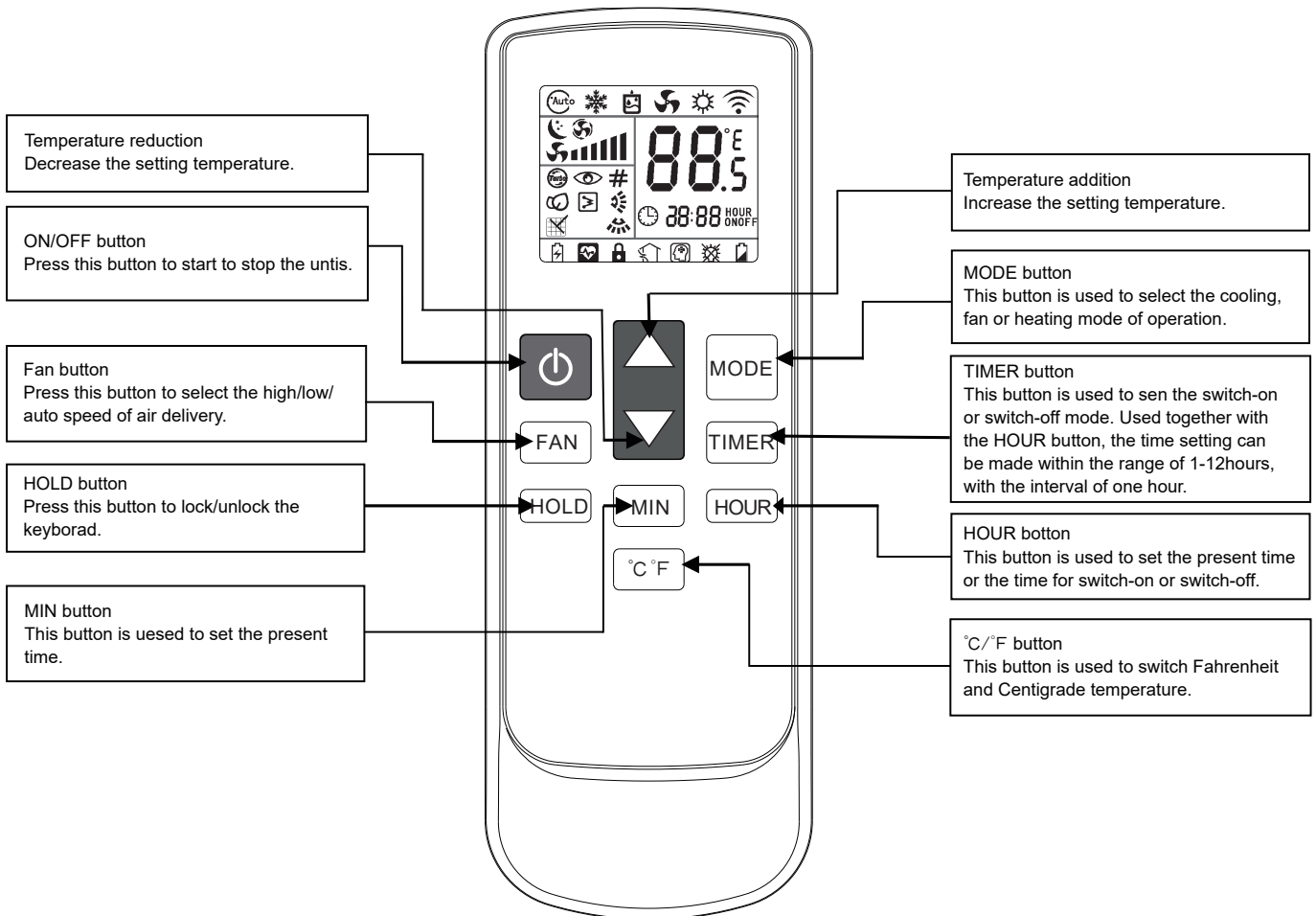

Fig 11 Use of hand held remote controller

OPERATING INSTRUCTIONS (ACCESSORY OPTIONAL)

SENIOR OPERATION

- 1) **Temperature shift key:** Press + and - button at the same time for 3 seconds, the temperature is shifted between Fahrenheit and centigrade.
- 2) **Temperature setting limiting:** Press + and SPEED button at the same time to enter the maximum and minimum temperature setting. R1~R8 will be display every 3 seconds. Relieve the two keys to ensure the setting effective and the figures will last for 5 seconds. The temperature setting range is between 6°F~90°F as factory default.

Chart. Temperature setting limiting

R1	R2	R3	R4	R5	R6	R7	R8
Heating Temperature Limits(°F)							
86	86	90	74	92	90	72	90
Cooling Temperature Limits(°F)							
63	65	72	72	67	69	68	60

VENTILATION CONTROL

The ventilation control lever is located at left side of unit, behind front panel.

NOTE: The vent door shipping tape must be removed before using vent control lever. See Fig 12 and Fig 13.

When set at close, only the air inside the room is circulated and filtered;

When set at open, some outdoor air will be drawn into room, this will reduce heating or cooling efficiency.

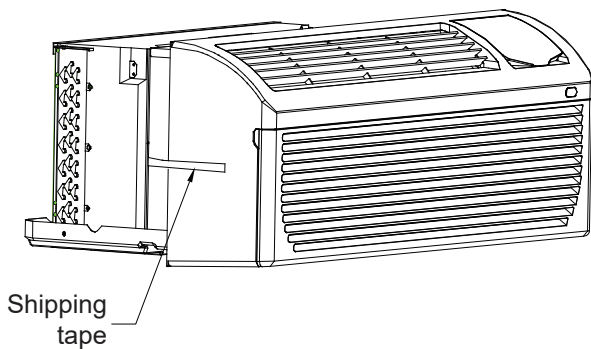

Fig 12 Shipping tape Location

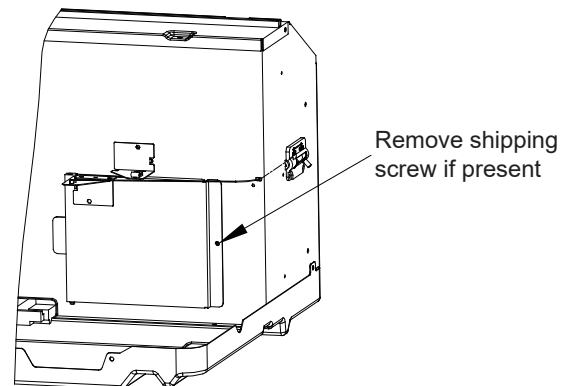

Fig 13 Shipping Screw Location

The vent control allows outside air to be drawn into the conditioned area. This outside air can provide ventilation when the blower is operating, but it will increase the heating or cooling load and operating costs.

To obtain access to the vent control

1. Remove the cabinet front (see Front Removal).
2. Remove the shipping screw (if installed) from the vent door.
3. Remove the label (if present) from over the vent control lever on the left side of the chassis. Remove the vent door shipping screw.
4. Rotate the vent control lever to either open or close the damper.

OPERATING INSTRUCTIONS (ACCESSORY OPTIONAL)

WARNING

HIGH VOLTAGE

DISCONNECT ALL POWER BEFORE SERVICING OR INSTALLING THIS UNIT. MULTIPLE POWER SOURCES BE PRESENT, FAILURE TO DO SO MAY CAUSE PROPERTY DAMAGE, PERSONAL INJURY OR DEATH.

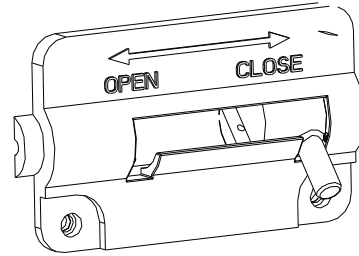
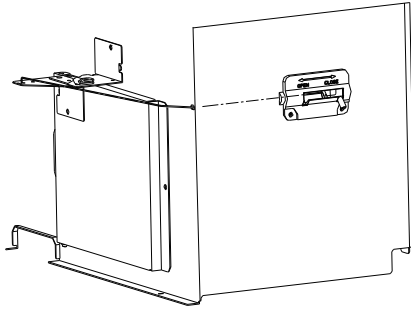

Vent door lever positions

AIR DISCHARGE GRILLE

The discharge grille can be adjusted to expel air at either a 15° or 55° angle.

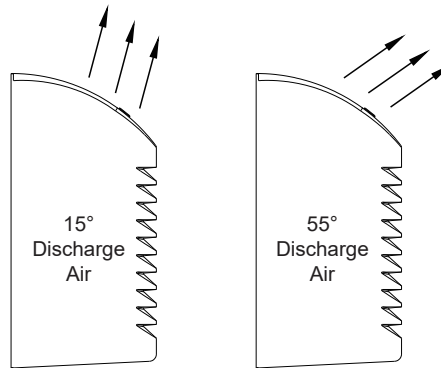

Discharge Grille Orientation Options

Use the following procedure to change the angle of the discharge air flow:

1. Remove the front cabinet (see Front Removal).
2. Position the front so that the backside is accessible.

Discharge Air Flow

3. Remove the seven (7) screws which secure the discharge air grille to the cabinet front.

Location of 7 Screws

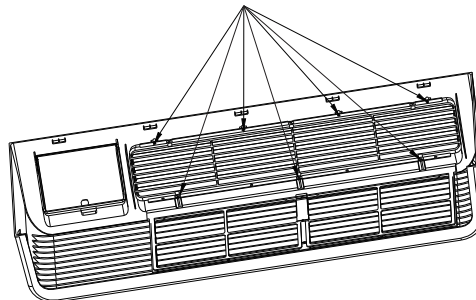

Discharge Air Flow Grille Removal

4. Rotate the grille 180° clockwise
5. Reinstall the screws securing the discharge air grille to the cabinet front. Reinstall the cabinet front on the unit.

WALL THERMOSTAT CONTROL

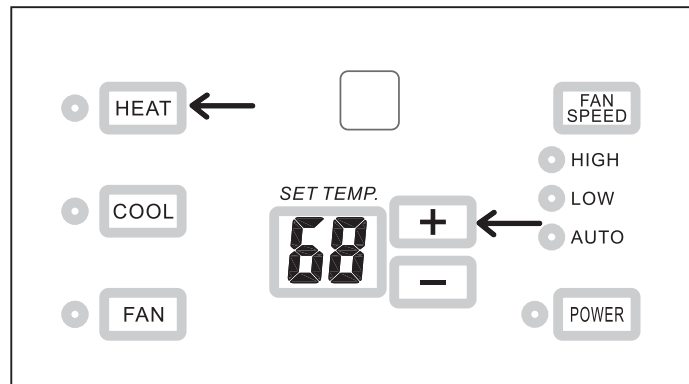

Remote thermostat change: On standby off mode, press HEAT and+ button, for 3 seconds, the buzzer will chime and LED display will read " P " or " ⌂ ".

P: unit control panel has control of unit.

⌂: wall thermostat has control of unit.

NOTE: In " ⌂ " mode (wall thermostat control), the display on the unit will have no control of unit. Only wall thermostat.



MAINTENANCE AND CLEANING

WARNING

HIGH VOLTAGE
DISCONNECT ALL POWER BEFORE SERVICING OR INSTALLING THIS UNIT. MULTIPLE POWER SOURCES BE PRESENT, FAILURE TO DO SO MAY CAUSE PROPERTY DAMAGE, PERSONAL INJURY OR DEATH.

MONTHLY MAINTENANCE AND CLEANING

Intake Air Filters

To properly maintain the operational performance of your PTAC unit, it is extremely important that the inlet air filters be cleaned once per month or more often if operated in dusty or dirty locations or conditions. The intake air filters are constructed of durable polypropylene. The "air intake" air filters can be easily inserted into the cabinet front, using the filter guides. Before cleaning the intake filter, turn the unit off by setting the mode switch to the OFF position. Filter should be cleaned as required.

The following procedure is used to remove the intake filter:

1. Grasp each filter by its molded handle, located on the front edge of the front, below the discharge grill.
2. Pull the filter straight up and remove.
3. Clean filter with vacuum or with running water.

Reverse this procedure to reinstall the filter.

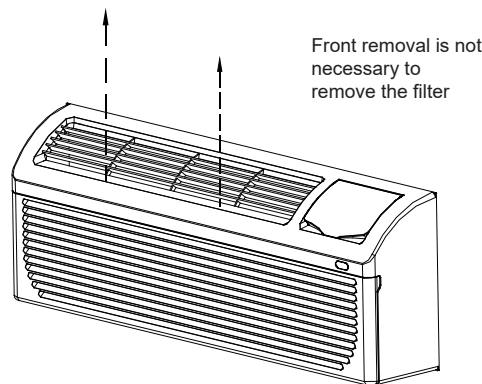

Vent Screen

Before cleaning the vent screen, disconnect power to the unit by unplugging the power cord at the wall outlet or subbase, or disconnect power at the fuse box or circuit breaker. If unit is operated with vent door closed, the vent screen does not need to be cleaned.

1. Remove the cabinet front as described in Front Removal.
2. Remove the six screws securing the chassis to the wall sleeve.
3. Slide the chassis out of the wall sleeve far enough so that the vent screen is accessible.
4. Clean the vent screen, slide the chassis back into the wall sleeve, secure it in place with six screws and reinstall the front cabinet.

Cabinet Front

The cabinet front and discharge air grille can be cleaned with a water dampened cloth. Under no circumstances should hydrocarbon-based cleaners (e.g. acetone, benzene, naphtha gasoline, etc.) or ammonia based cleaners be used to clean the front or air grilles. Use care when cleaning the control area.

YEARLY MAINTENANCE AND CLEANING

NOTE: Use a mild biodegradable detergent when cleaning the unit. Special care must be taken to protect the unit's control board and other electrical components from getting any water on them while cleaning. The use of harsh or caustic cleaning agents or materials such as bleach or coil cleaners that are not designed for PTAC products will cause damage or deterioration of the aluminum fin or coil material and is not recommended. Care must be taken not to bend the aluminum fin stock.

MAINTENANCE AND CLEANING

Routine scheduled Maintenance

To achieve continuing top performance and high efficiency, establish a “once a year” cleaning/inspection schedule for the unit. Take the unit out of the sleeve and thoroughly clean and rinse. Be sure to include in the yearly cleaning the evaporator coil, and condenser coil, basepan, and drain passages.

Scheduled maintenance can be accomplished by either qualified local maintenance staff or by an authorized servicer. They must follow the instructions described in this manual.

Adverse Operating Conditions Maintenance

Units operating in dusty or corrosive locations; i.e. dusty construction site or sea coast, must be cleaned more often. A minimum of four (4) times a year will maintain proper operational conditions and protect unit components.

Wall sleeve

Clean the wall sleeve while cleaning the unit. The caulking around the sleeve should be checked to make sure that any potential air and water openings around the sleeve are properly sealed. The wall sleeve's level should also be rechecked. Proper leveling for most installations are a 1/4 bubble tilt to the outside and level from right to left. Contact your sales person for detailed maintenance or cleaning instructions.

WARNING

DO NOT USE COMMERCIAL GRADE COIL CLEANERS. SOME OF THESE CLEANERS MAY CONTAIN ETHYLENE DIAMINE TETRACETIC ACID (EDTA) WHICH CAN SHORTEN THE LIFE OF THE CONDENSER COIL.

Base pan and Condenser coil

Before cleaning the base pan and condenser coil, turn OFF unit mode switch and disconnect power to the unit.

To disconnect power, either unplug the power cord at the wall outlet or subbase, or disconnect power at the fuse box or circuit breaker.

1. Create a water tight seal by tightly covering the entire control panel area and fan motor with plastic. Creating this seal prevents water from entering the control area or the fan motor and damaging the unit.
2. Spray condenser coil and base pan down with water. Next spray a mild biodegradable detergent onto the condenser coil and base pan. Let set for five (5) minutes.
3. Rinse condenser coil and base pan with water again.

NOTE: Ensure water pressure is no higher than that of an ordinary garden hose and the water temperature no higher than 120°F.

4. Tilt the non-compressor side of the unit up no higher than 45 degrees and allow water to drain out the other side of the unit.
5. Remove excess water left in the base pan by wiping the base pan with a dry cloth.
6. Remove the water-tight seal from the motor and control panel area.
7. Reinstall unit back into wall sleeve.
8. Allow unit to dry for 24 hours before reapplying power. When power is reapplied test unit for proper operation.
9. Place a non-acidic algaecide in the base pan to inhibit bacteria growth. Ensure the algaecide is compatible with wet coil operation and is not corrosive to the coil.

WARNING

HIGH PRESSURE AND HIGH TEMPERATURE CLEANING IS NOT RECOMMENDED. DOING SO COULD DAMAGE THE ALUMINUM FIN STOCK AND ELECTRICAL COMPONENT.

Clearance Check

Clearances around the unit should also be checked to make sure that the intake air and discharge air paths have not become blocked or restricted. A minimum of eight inches clearance is needed from unit to furniture, beds, or other objects for proper operation. Restricted discharge or intake air will reduce the unit's operational performance. In severe airflow restrictions damage can occur to unit components such as the compressor, electric heater or fan motor.

NORMAL OPERATING SOUNDS AND CONDITIONS

Water trickling sounds

Water is picked up and distributed over the coil. This improves the efficiency and helps with water removal.

Water dripping

Water will collect in the base pan during high humidity days. This can cause overflow and drip from the outside of the unit.

Air sounds

The fan cycle switch sets the operational mode of the fan. In the ON position the fan will run continuously whenever power is applied in this mode. In the AUTO position, the fan will cycle on and off with the compressor or electric heater.

Starting delay

You may notice a few minutes delay in the starting if you try to restart the unit too soon after turning it off or if you adjust the thermostat right after the compressor has shut off. This is due to a built-in delay to protect the compressor.

Buzzer Response

The buzzer will chime "Di"(0.1 sec) as response when receiving the effective order from key pad control and remote control.

DIAGNOSTIC CODES

The Diagnostic Maintenance provides detailed information on PTAC control operation and operational status including present modes, failures, airflow restriction warnings, operating temperatures, and past failures.

To enter Diagnostic Status Report mode, press and hold the down arrows and, while hold press the FAN SPEED key for a period of five (5) seconds.

The meaning of figure on display pad is as below:

X.X ---- (0~4: time of protection)

└ — is protection mode(1: anti-frost; 2: overheat; 3: high pressure; 4: anti-freezing)

Protective Auto Diagnostics

Failure code	Content of defect
E2	Indoor temperature sensor failure
E3	Indoor coil temperature sensor failure
E4	High temperature protection of air outlet
E5	Outdoor coil temperature sensor failure
E7	Failure of air outlet temperature sensor
E8	Overheating protection/defrosting
E9	High temperature protection of outdoor coil
F6	Indoor fan zero-crossing failure
F8	Internal fan secular malfunction

TROUBLE SHOOTING

POSSIBLE CAUSES	SOLUTIONS
<p>UNIT DOES NOT START</p> <ul style="list-style-type: none"> • Unit may have become unplugged • Fuse may have blown • Circuit breaker may have been tripped • Unit may be off or in wall thermostat mode. <p>Check section on dipswitch settings to verify dipswitches are set properly.</p> <ul style="list-style-type: none"> • Unit may be in a protection or diagnostic failure mode. See section on diagnostic codes. 	<ul style="list-style-type: none"> • Check that plug is plugged securely in wall receptacle. <p>Note: Plug has a test/reset button on it. Make sure that the plug has not tripped.</p> <ul style="list-style-type: none"> • Replace the fuse. • Reset circuit breaker. • Turn unit on (bottom right button on keypad).
<p>DISPLAY HAS STRANGE NUMBERS/CHARACTERS ON IT</p>	<ul style="list-style-type: none"> • The unit may be in a diagnostic condition. Check diagnostic codes --- checking Control section to determine if unit has had a failure. • The unit may be set for °C (instead of °F), see the SENIOR OPERATION.
<p>UNIT MAKING NOISES</p>	<ul style="list-style-type: none"> • Clicking, gurgling and whooshing noises are normal during operation of unit.
<p>UNIT NOT COOLING / HEATING ROOM</p> <ul style="list-style-type: none"> • Unit air discharge section is blocked. • Temperature setting is not high or low enough. Note: Setpoint limits may not allow the unit to heat or cool the room to the temperature desired. Check section on dip-switch settings. • Unit air filters are dirty. • Room is excessively hot or cold when unit is started. • Vent door left open. • Unit may be in a protection or diagnostic failure mode. Check section on Intelligent Self --- checking Control. • Compressor is in time delay. There is a protective time delay (approx. 3 minutes) on starting the compressor after a power outage(or restarting after it has been turned off), to prevent tripping of the compressor overload. 	<ul style="list-style-type: none"> • Make sure that curtains, blinds or furniture are not restricting or blocking unit airflow. • Reset to a lower or higher temperature setting. • Remove and clean filters. • Allow sufficient amount of time for unit to heat or cool the room. <p>Start heating or cooling early before outdoor temperature, cooking heat or gatherings of people make room uncomfortable.</p> <ul style="list-style-type: none"> • Close vent door. • Check DIP switch settings for desired comfort. • Wait approximately 3 minutes for compressor to start.
<p>WATER DRIPPING OUTSIDE</p>	<ul style="list-style-type: none"> • If a drain kit has not been installed, condensation runoff during very hot and humid weather is normal. See Note 2. If a drain kit has been installed and is connected to a drain system, check gaskets and fittings around drain for leaks and plugs.
<p>WATER DRIPPING INSIDE</p> <ul style="list-style-type: none"> • Wall sleeve is not installed level 	<ul style="list-style-type: none"> • Wall sleeve must be installed level for proper drainage of condensation. Check that installation is level and make any necessary adjustments.
<p>ICE OR FROST FORMS ON INDOOR COIL</p> <ul style="list-style-type: none"> • Low outdoor temperature • Dirty filters 	<ul style="list-style-type: none"> • When outdoor temperature is approximately 55°F (12.8°C) or below, frost may form on the indoor coil when unit is in Cooling mode. Switch unit to FAN operation until ice or frost melts. • Remove and clean filters.
<p>COMPRESSOR PROTECTION</p> <ul style="list-style-type: none"> • Power may have cycled, so compressor is in a restart protection. 	<ul style="list-style-type: none"> • Random Compressor restart — Whenever the unit is plugged in, or power has been restarted, a random compressor restart will occur. After a power outage, the compressor will restart after approximately 3 minutes. • Compressor Protection — To prevent short cycling of the compressor, there is a random startup delay of 3 minutes and a minimum compressor run time of 3 minutes.

CONTACT INFO

1-204-201-0717

1-866-233-4022(toll free)

info@genuinecomfort.com

377 Henderson Hwy, Winnipeg, Manitoba R2K 2H2

www.genuinecomfort.com

GC-SMS-PT-ENG02.V0

8020220A5262