

Model PCNTB Series

- 26" Packaged Terminal Air Conditioners

Features

- Environmentally friendly R410A Refrigerant
- Attractive appearance
- Four fan speeds: Auto/Lo/Med/Hi
- Industry standard wall sleeve (optional)
- 26 1/4" (W) x 16 1/2" (H) x 16" (D)
- Electronic touch pad thermostat
- Hand held controller
- Slide-out chassis
- Efficient rotary compressor
- 4-way adjustable air discharge
- Hidden vent control
- Energy-saver mode
- Easy to clean filter

MODEL IDENTIFICATION

Perfect Comfort	PC	NTB	12	K	3	C	4	D	Digital Controls
26" Thru The Wall Series									Development Series
Cooling Capacity									Type:
09:9,000 BTU/H									C: Cooling
12:12,000 BTU/H									H: Heat Pump
Voltage: L: 115v K: 208/230V									Electric Heater Size
									1: 1.1 KW
									3: 2.9 KW / 3.5 KW

Wall Sleeve Dimensions

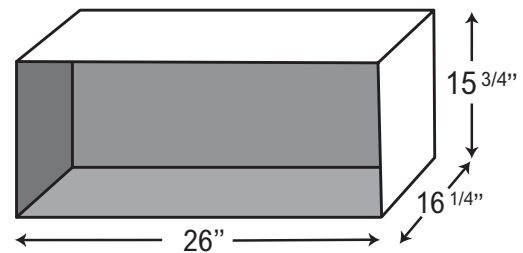

Hand Held Remote with Digital Controls

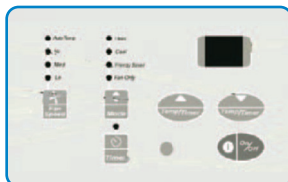

The Perfect Fit! The Perfect Choice!

For more information

Call 1-866-233-4022

Email info@perfectcomfort.ca

www.perfectcomfort.ca

We are your best source for reliable products and superior customer service.

Specifications

	PCNTB09L1H4D Heat Pump	PCNTB09K3C4D Electric Heat	PCNTB12K3C4D Electric Heat
General features			
Voltage	115	230/208	230/208
Approx. chassis weight	79 lbs	77 lbs	79 lbs
Approx. shipping weight	92 lbs	90 lbs	98 lbs
Refrigerant			
Capacity / BTUH	9,000	9,200/8,900	11,800/11,400
Amps	8.8	4.4/4.7	5.6/6.0
Watts	960	940/910	1,200/1,160
CFM	270 Hi/225 Low	270 Hi/225 Low	270 Hi/225 Low
E.E.R.	9.4	9.8/9.8	9.8/9.8
Dehumidification - pts/hr	2.5	2.5	3.4
Electric Heat			
Capacity / BTUH	3,900	11,000/9,000	11,000/9,000
Amps	11.0	15.0/14.0	15.0/14.0
Watts	1,150	3,500/2,900	3,500/2,900
Heat Pump (Reverse Cycle)			
Capacity / BTUH	8,500	n/a	n/a
Amps	7.7	n/a	n/a
Watts	860	n/a	n/a
C.O.P.	2.9	n/a	n/a
Adjustable changeover thermostat	Yes	n/a	n/a
Thermostatic drain valve	Yes	Yes	Yes
Heat Pump (Reverse Cycle)			
Circuit Breaker Size	5-15P	6-20P	6-20P
Plug Type	Parallel	Perpendicular	Perpendicular

DIMENSIONS OF WALL OPENING

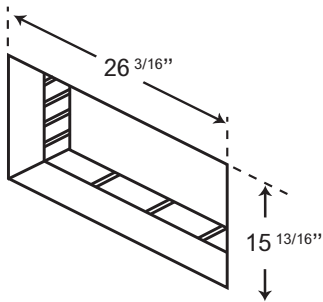

Wall opening of 26 3/16" x 15 13/16" is required.

Be sure to use lintel to support the block and brick above the sleeve to retain the weight of the unit.

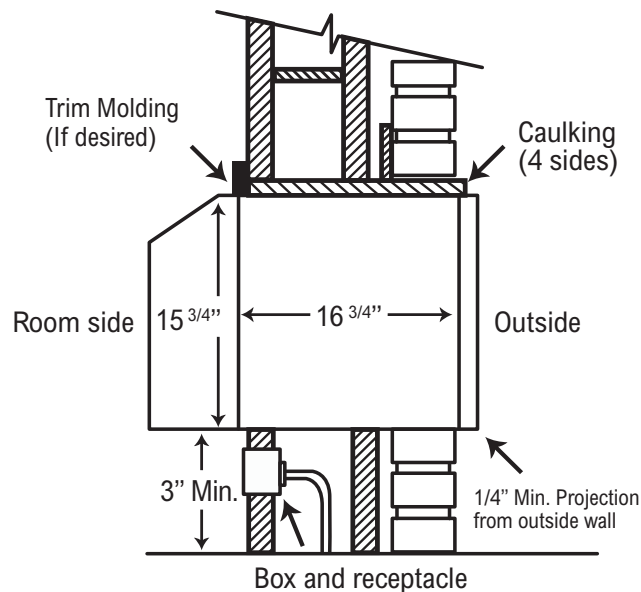

WALL RECEPTACLES

Parallel



115 V
15AMP

Perpendicular



230/208V
20AMP

For more information

Call 1-866-233-4022
Email info@perfectcomfort.ca
www.perfectcomfort.ca

PERFECT
Comfort
YOUR HVAC SUPPLIER

DISTRIBUTED BY:

Manufacturer reserves the right to change specifications. Our products are subject to continuous improvements, Perfect Comfort / NRG Equipment reserves the right to modify product design and specifications, discontinue design without notice and without incurring any obligations.