



### Model PCVT Series

- 23 1/8" Vertical Terminal Air Conditioner

### Features

- Standard model with heat pump
- 24V Thermostat Compatible
- Compressor restart Delay
- Evaporator Coil Freeze Protection
- "Ductable" to multiple rooms
- Auto Re-Start
- Room Freeze Protection
- Easy reachable disconnect switch
- Silent Operation
- Easy installation and Maintenance

### Accessories:

- Architectural Grill
- Duct Transition
- Telescope Extension
- 24V Thermostat (wired/wireless) - Optional



The Perfect Fit! The Perfect Choice!

For more information

Call 1-866-233-4022

Email [info@perfectcomfort.ca](mailto:info@perfectcomfort.ca)

[www.perfectcomfort.ca](http://www.perfectcomfort.ca)

# Specifications

Unit Electrical Ratings (Heat Pump)	PCVT09K3HT1	PCVT12K3HT1	PCVT17K5HT1
BTU (Heating)	8500/8300	10500/10300	15700/15500
Input Watts	710/685	880/860	1395/1375
COP	3.5/3.5	3.5/3.5	3.3/3.3
BTU (Cooling)	9300/9100	11500/11500	16600/16600
Input Watts	770/750	990/990	1510/1510
EER	12.1/12.1	11.6/11.6	11.0/11.0
Unit Electrical Ratings			
Max.A	17	17	23
MAX HACR BRKR	20	20	30
Electric Heat			
Heater KW	3.6KW	3.6KW	5KW
Volt	208/230	208/230	208/230
Indoor Fan Motor			
FLA	0.56	0.56	0.56
HP	0.1	0.1	0.1
CFM	350/295	390/295	480/390
Outdoor Fan Motor			
FLA	0.37	0.37	0.37
HP	0.1	0.1	0.1
Power Supply Voltage			
Volt	208/230	208/230	208/230
MIN	197	197	197
Compressor			
RLA	3.5	4.4	6.55
LRA	16.5+/-10%	29.5+/-10%	36+/-10%
Unit			
Packing (W*H*D)	28"*36"*28"	28"*36"*28"	28"*36"*28"
Net/Gross Weight	76/84kg	79/87kg	83.5/91.5kg

## DIMENSIONS OF WALL OPENING

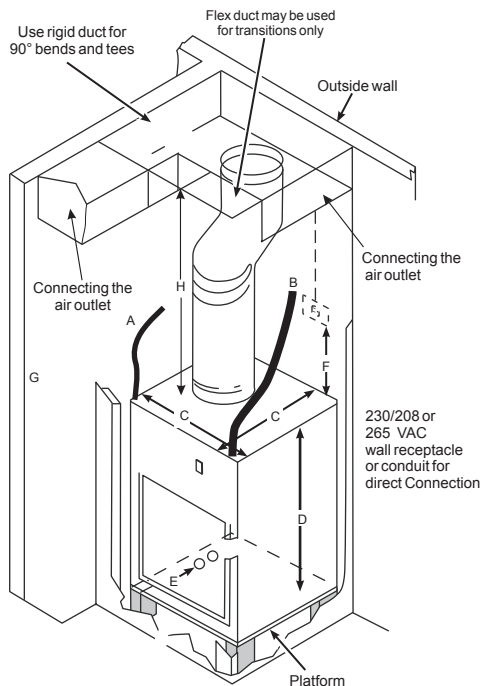

## Installation Sketch

### Reference Dimensions

- A Thermostat cable
- B Hard Wired Power Supply
- C Case width and depth: 23-1/8"
- D Case height: 31"
- E Condensate drains: 3/4" connector
  - Primary Drain - Centerline of cutout is approximately 5-1/4" from left case wall and 8-1/2" from back case wall.
  - Secondary Drain-centerline of cutout is approximately 6-1/2" from left case wall and 5-1/4" from back case wall.
- F Typical wall plug: 6"-12" above case
- G Room air sensor kit: 10' long.
- H 40" min.

## PCVT MODEL CODING

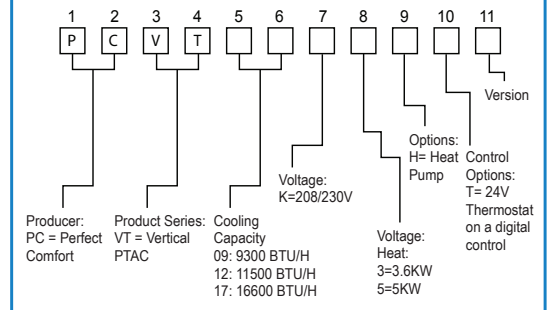

For more information

Call 1-866-233-4022  
Email [info@perfectcomfort.ca](mailto:info@perfectcomfort.ca)  
[www.perfectcomfort.ca](http://www.perfectcomfort.ca)



DISTRIBUTED BY:

Manufacturer reserves the right to change specifications. Our products are subject to continuous improvements, Perfect Comfort / NRG Equipment reserves the right to modify product design and specifications, discontinue design without notice and without incurring any obligations.